

MARQUEE

MT-10S

COMMERCIAL EMBROIDERY MACHINE
WITH INTUITIVE 10.1" HIGH-DEFINITION TRUE-COLOR TOUCH SCREEN



MAIN FEATURES

The MT-10S has a wide range of capabilities and functions that make it perfect for any business, big or small.

- Suitable for embroidery on flats, caps, finished garments and more!
- Perfect for small and established businesses alike
- 3 models allow for mass production
- High-Definition True-Color 10.1-inch LCD Touch Screen
- Maximum embroidery area: 500 x 360 mm (19.7 x 14.2 in)
- Maximum speed: 1200 spm for 1 head model and 1000 spm for 2 & 3 head models
- Large memory capacity: 100 million stitches or 1000 designs
- Machine reads multiple design formats such as DST, DSB, TBF and more
- Wide angle cap system: 270°
- Smaller sewing arm greatly improves the performance of cap embroidery and embroidery on small items
- Heavy-duty steel stand with wheels for both stability and mobility
- Multiple hoop sizes for a variety of embroidery needs
- Wide overhead arm system for easy embroidery on bulky items
- Automatic color change
- Automatic thread trimmer
- Reinforced upper thread clamp to ensure stable trimming
- Thread break detection
- Networkable – USB input or direct transmission from PC via LAN port
- Design transfer via Wi-Fi from Chroma software to 10S panel
- Easily add appliqué, sequin or cording
- Frame offset and frame outlining are available for easy appliqué embroidery
- Automatic memory retention
- One-step tracing button on home screen
- Adjustable control panel positioning for better visibility and comfort
- Built-in button from 172° to 196° under manual color change mode to help with machine maintenance
- Recessed USB port to protect USB flash drive
- Multiple languages: English, Chinese, Spanish
- Servo motor 150W – lowest power consumption in the industry!
- Built-in universal power supply, 110V/60Hz and 220V/50Hz self-adaptable worldwide
- DC36V micro-step motor for X & Y axis driving ensures low noise and less vibration
- Compatible with optional laser tracing device
- Double LED lights for a wider field of view
- Front LED lamp provides better visibility and protection for eyes against strong light during threading
- Conveniently placed power on/off switch on right side of machine
- Environmentally friendly packaging
- Perfect for mass production of patches
- Slim machine width allows for easy entry through standard-sized doors



FRAME OFFSET AND FRAME OUTLINING



AUTOMATIC COLOR CHANGE



10" USER-FRIENDLY TOUCH PANEL

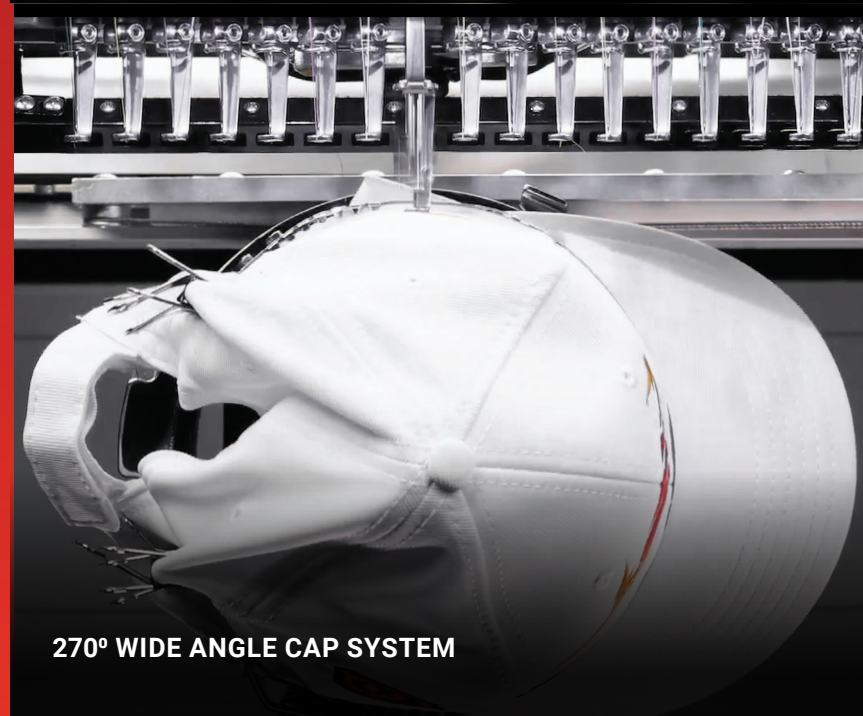

270° WIDE ANGLE CAP SYSTEM

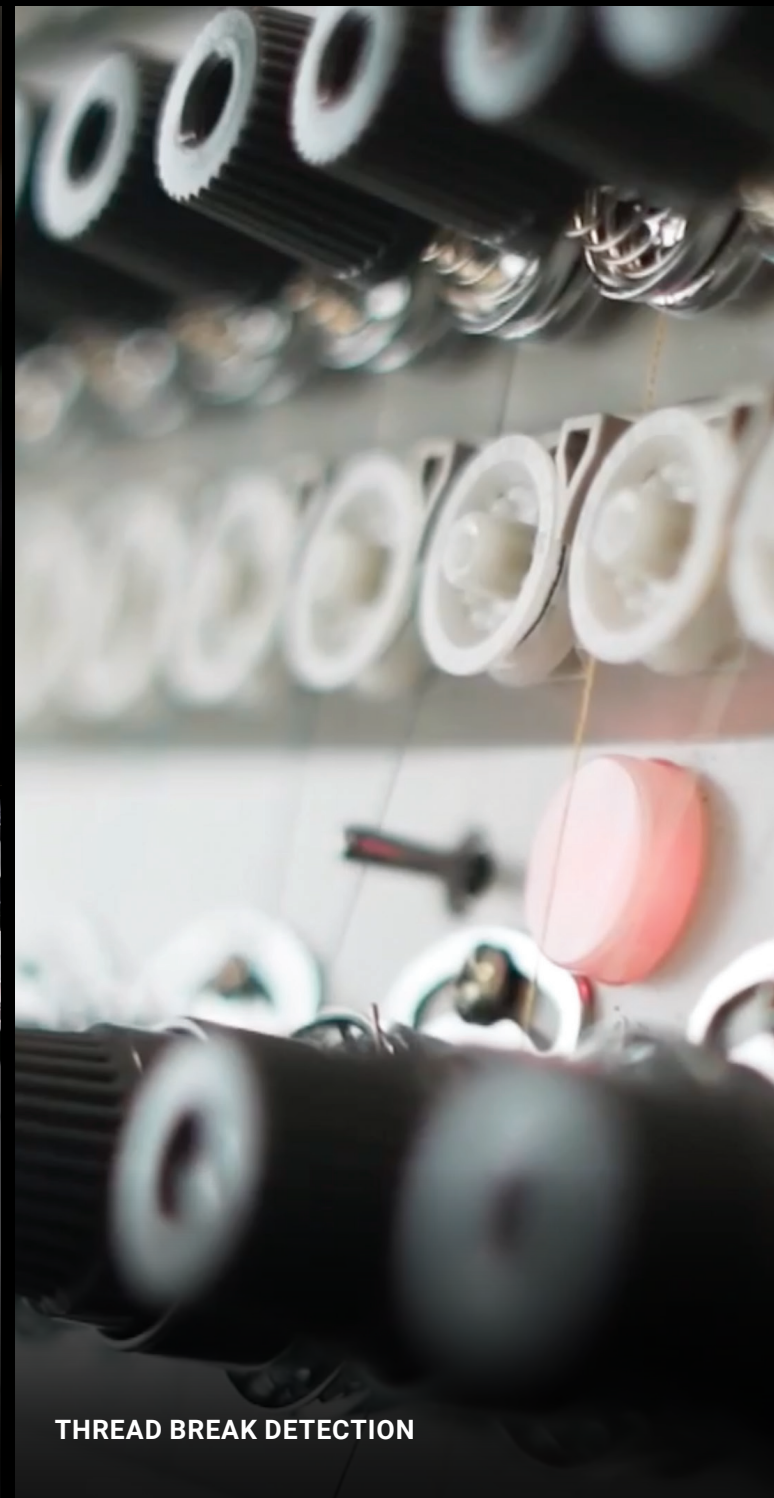

THREAD BREAK DETECTION

EMBROIDERY SOLUTIONS FOR PROS

TECHNICAL SPECIFICATIONS

Machine Name	MT 10S Single-Head	MT 10S Two-Head	MT 10S Three-Head
Model	MT-1501/MT-2001	MT-1502/MT-2002	MT-2003
Panel	High-Definition True-Color 10.1" LCD Touch Screen	High-Definition True-Color 10.1" LCD Touch Screen	High-Definition True-Color 10.1" LCD Touch Screen
Heads	1	2	3
Needles	15 / 20	15 / 20	20
Machine Size With Stand (L*W*H)	830 x 770 x 1600 mm (32.7 x 30.3 x 63 in)	1430 x 770 x 1600 mm (56.3 x 30.3 x 63 in)	1910 x 770 x 1620 mm (75.2 x 30.3 x 63.8 in)
Net Weight	145 kgs (319.7 lbs)	190 kgs (418.9 lbs)	390 kgs (859.8 lbs)
Gross Weight	210 kgs (463 lbs)	320 kgs (705.5 lbs)	580 kgs (1278.7 lbs)
Embroidery Area	500 x 360 mm (19.7 x 14.2 in)	500 x 360 mm (19.7 x 14.2 in)	500 x 360 mm (19.7 x 14.2 in)
Head Interval	n/a	605 mm (23.9 in)	605 mm (23.9 in)
Cap Embroidery Area	270°	270°	270°
Maximum Speed	1200 spm	1000 spm	1000 spm
Voltage	90-240 vW	90-240 v	90-240 v
Power Consumption	0.2 kw	0.2 kw	0.3 kw
Memory Capacity	100 million stitches or 1000 designs	100 million stitches or 1000 designs	100 million stitches or 1000 designs

INTELLIGENT TECHNOLOGY

HIGH-TECH FEATURES TO EXPAND YOUR CAPABILITIES!



EMBROIDERY'S NEW FRONTIER

PERFECT FOR CUSTOM APPAREL BUSINESS OWNERS

This MT-10S has one of the largest clearance areas in the industry, making it easy to expand your business's product offerings with bulky, oversized items like bags, jackets and much more. Plus, with the ability to choose between 15-needle machines and the industry's first and only 20-needle models, you'll be able to decorate with an array of different colors in ultra-fast speeds, maximizing your productivity and profit potential with each head. Whether you operate an at-home business or a full-scale shop, the MT-10S is the perfect addition to your embroidery business.

Simplexity TECHNOLOGY

INTRODUCING THE NEWEST 10.1-INCH TOUCHSCREEN PANEL

The 10S model boasts an impressive 10.1-inch touchscreen panel that is intuitive and user-friendly. You'll enjoy the convenience of its **simple user interface** which makes it incredibly easy to navigate the machine's numerous functions and tools.

Powered by its innovative **Simplexity** technology, the 10S panel has a built-in **Tool Tips function** and a **help center** to provide an explanation of the selected option on the screen. Knowing what a specific tool does is an excellent way to quickly learn about your machine's capabilities, prevent user errors, and create an efficient workflow.

Additionally, the new **maintenance alert feature** does the thinking for you to remind you when basic maintenance needs to be done on your machine to reduce the learning curve and help your machine run smoothly.

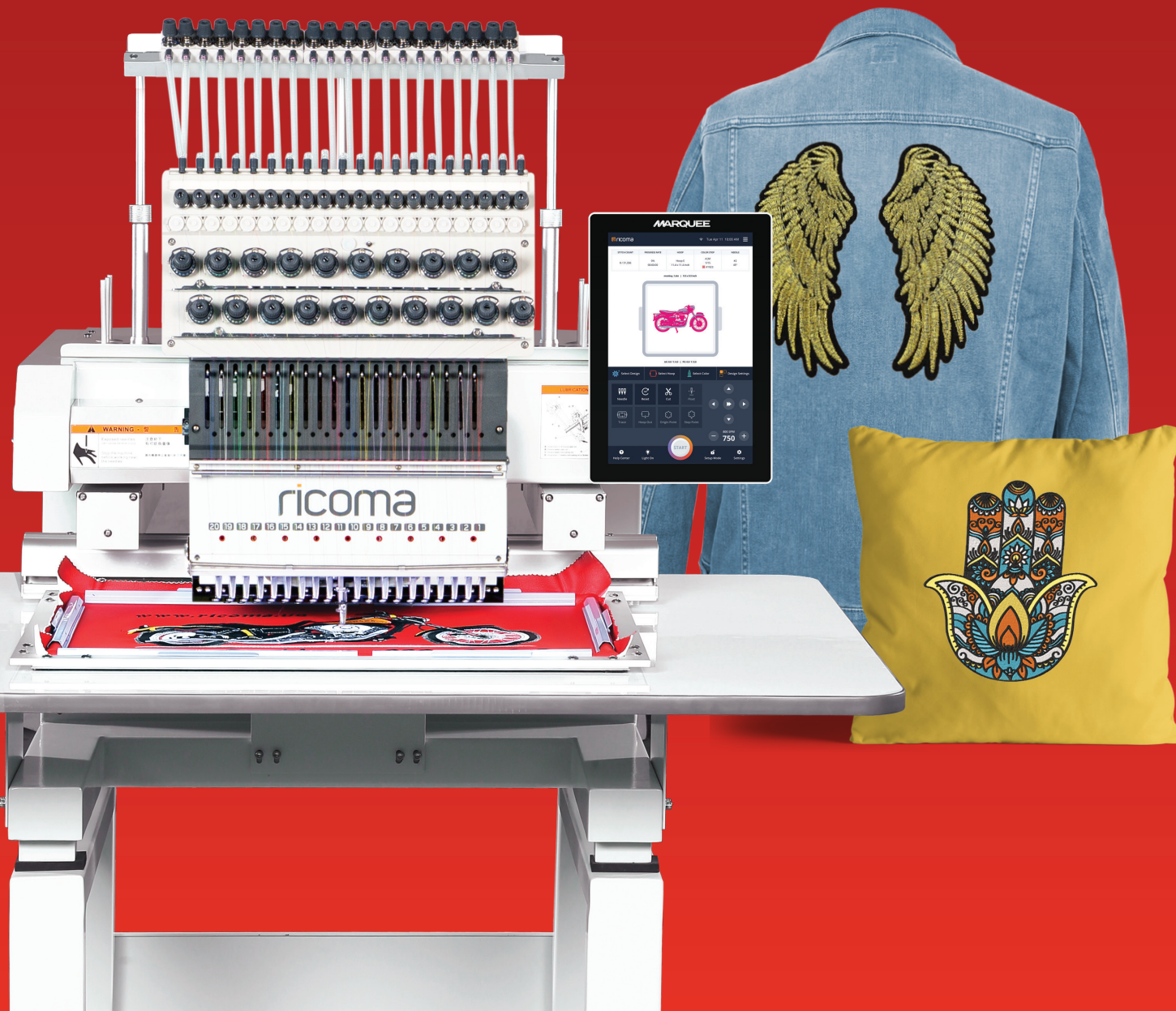

PANEL FEATURES

TECHNICAL SPECIFICATIONS

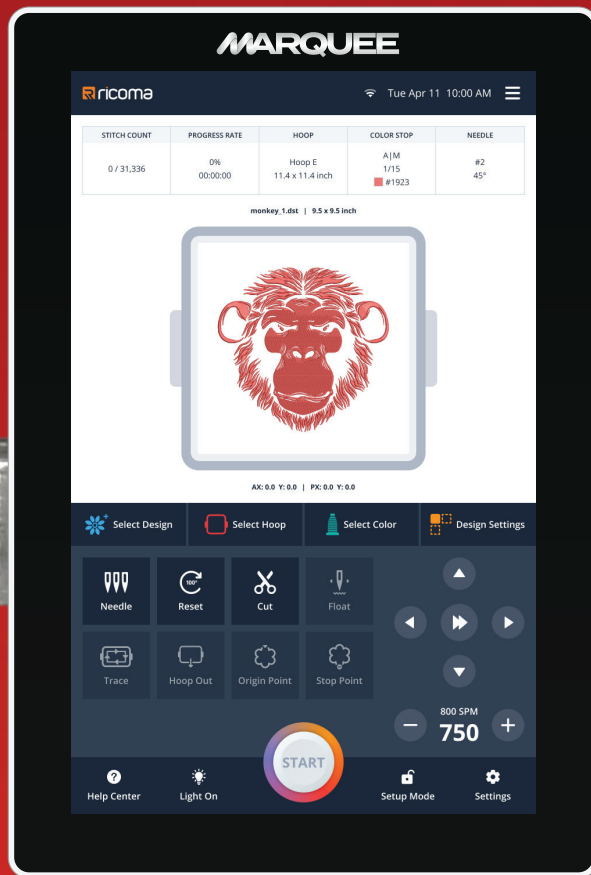

- Large memory capacity: 100 million stitches or 1000 designs with a maximum of 1000 automatic color changes

- Machine reads multiple design formats such as DST, DSB, TBF and more

- Easy to operate

- Full touch capacitive screen supports multi-touch and sliding screen operation

- Frame offset and frame outlining are available for easy appliqué embroidery

- Preset hoop parameters, which are designed to avoid hitting hoop frames

- Networkable – USB input or direct transmission from PC via LAN port

- Automatic color change

- Simplify machine maintenance with built-in 172-degree and 196-degree keys

- Generate new designs by adjusting the parameters and dimensions of pre-existing patterns

- Automatic thread trimmer

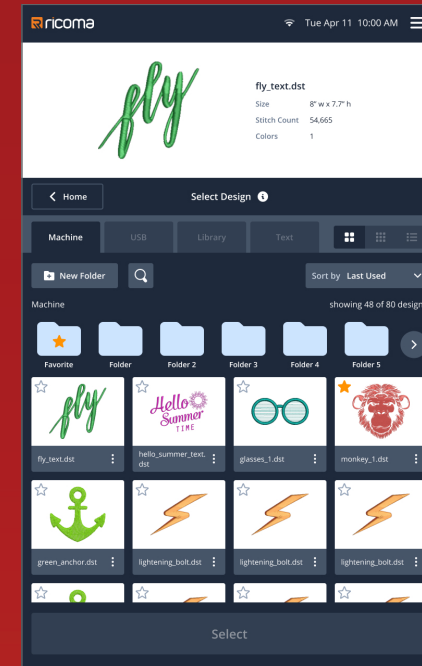

Select Design

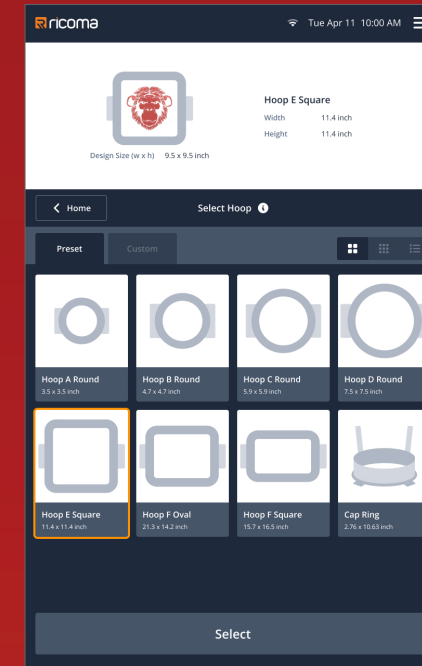

Select Hoop

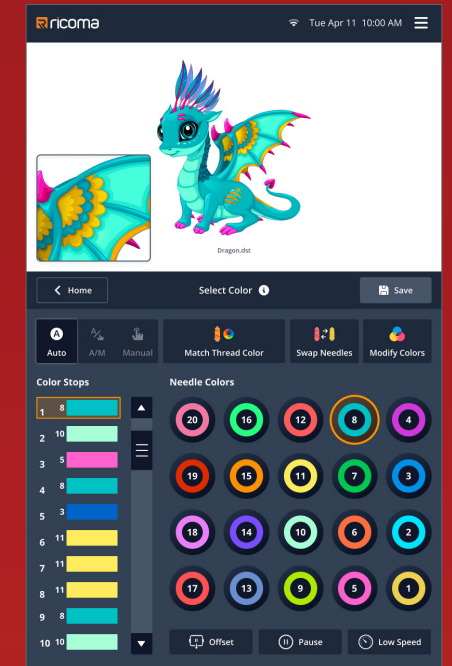

Select Color

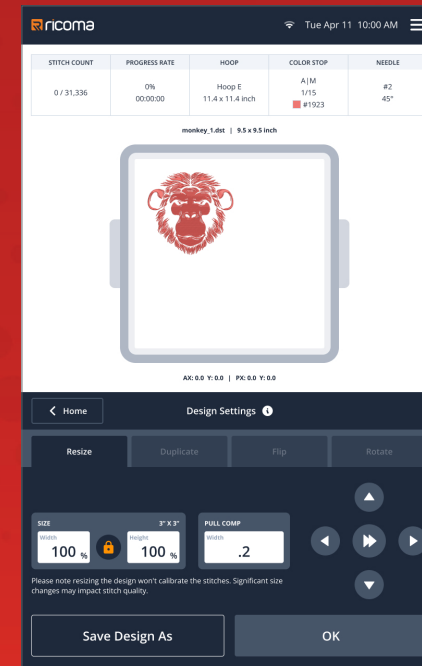

Design Settings

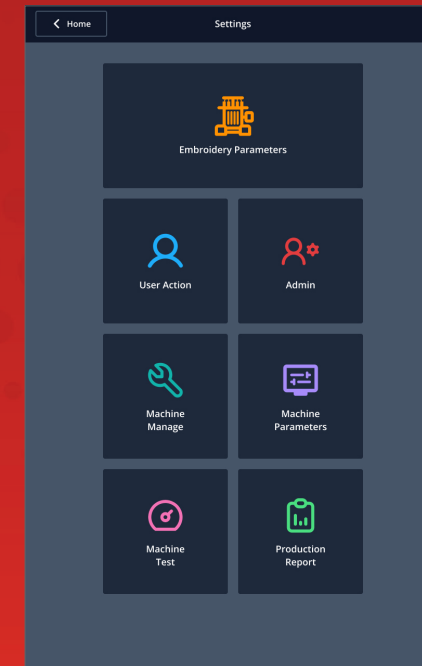

Machine Settings

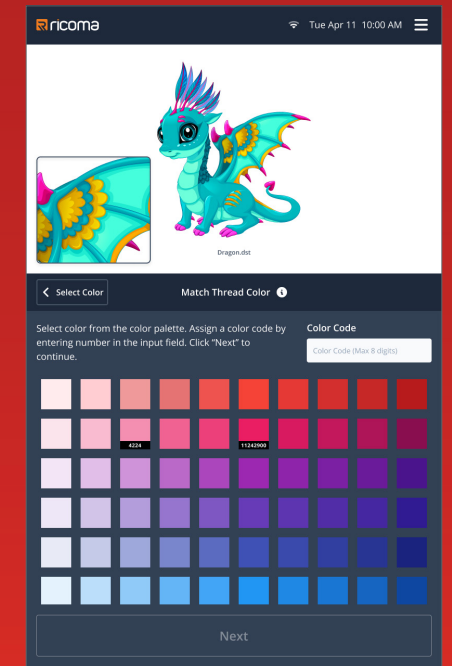

Match Thread Colors

PANEL FEATURES (CONT'D)

- Embroidery starting point saved to the machine's memory to increase efficiency

- Built-in factory mode, standardizing outgoing quality control process

- Easily access 24 different fonts to create custom words and phrases

- Machine parameters can be exported and imported for easy maintenance

- Repeatedly embroider the same design multiple times to increase productivity with repetition embroidery, which can also be used with cyclic embroidery

- Built-in screenshot function

- Cyclic embroidery function automatically returns the machine to the origin point and starts the same embroidery process again

- Optional laser trace device available

- Computer, encoder and main shaft testing are available to make maintenance and debugging more convenient

- Built-in file management system

- Automatic speed adjustment from one needle to the next

- Import & outport embroidery parameter

- Export system log function

- Machine maintenance reminder

- Customize distinct alert sounds for different fault alarms to easily identify issues

- Change the background on the hoop in the panel to ensure the design stands out

- Dynamic display of color sequence steps for easy color sequence setting

- Design management supports sorting and searching functions

- Screen saver function: adjust screen saver time, picture and display brightness

- Support switching between metric and imperial units

- Choose between light mode and dark mode settings depending on your preference

- Combine different embroidery patterns

- Built-in help function

- Multiple languages: English, Chinese, Spanish

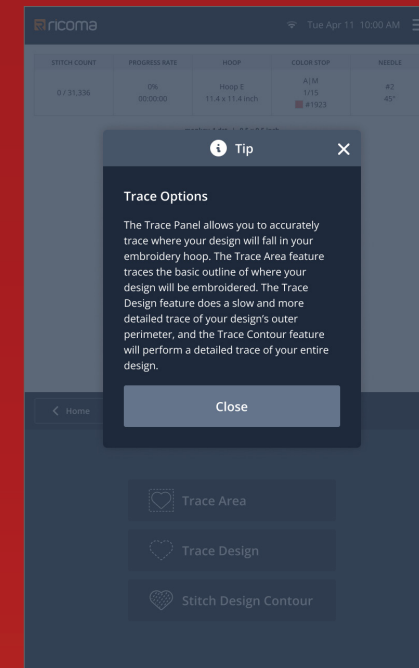

Tool Tips

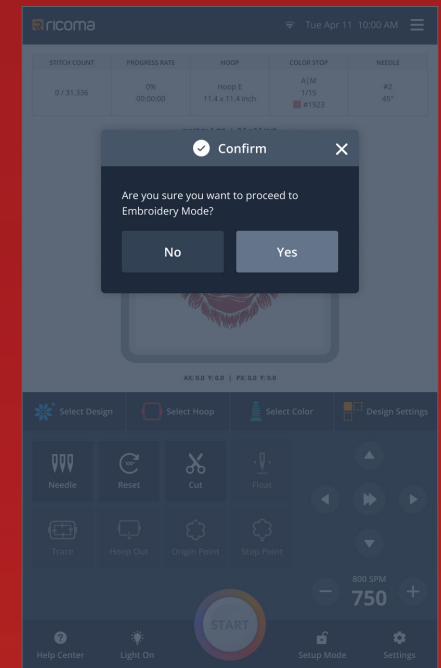

Confirmation Pop-ups

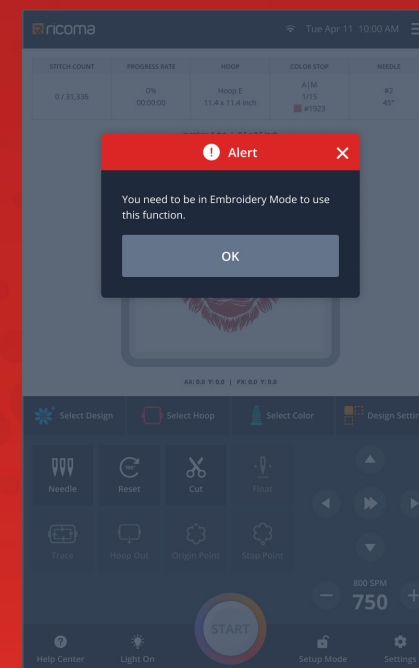

Pop-up Alerts

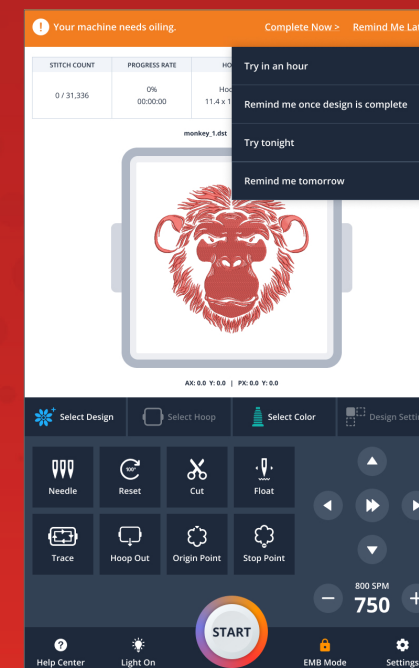

Machine Maintenance Reminders

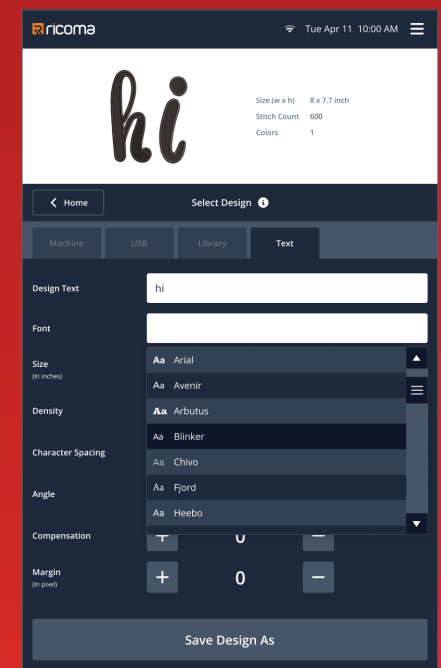







Multiple Fonts Available

HOOPS & CAP ATTACHMENTS

A RANGE OF HOOP SIZES AND SASH FRAMES TO FULFILL THE NEEDS OF YOUR BUSINESS

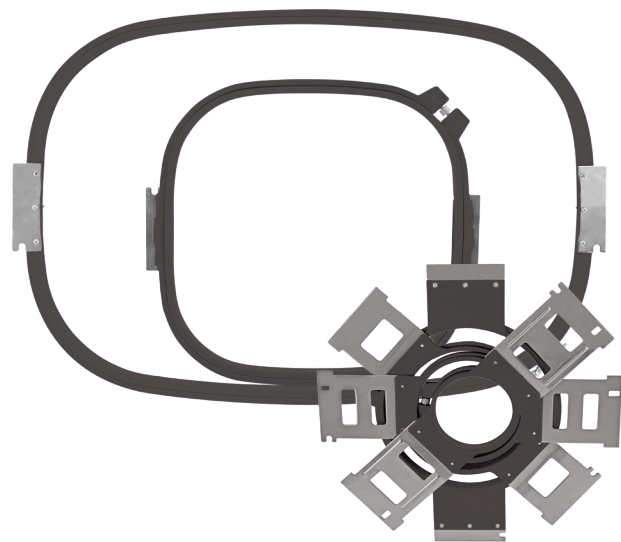

The MT-10S comes with everything you need to embroider just about any item so that you can meet the needs of every customer. Each machine includes a variety of hoop sizes for embroidering small designs like left-chest logos and large designs on bags, towels and more.

Models	Hoop A  90 x 90 mm (3.5 x 3.5 in)	Hoop B  120 x 120 mm (4.7 x 4.7 in)	Hoop C  150 x 150 mm (5.9 x 5.9 in)	Hoop D  190 x 190 mm (7.5 x 7.5 in)	Hoop E  290 x 290 mm (11.4 x 11.4 in)	Hoop F  540 x 360 mm (21.3 x 14.2 in)
MT-1501-10S	x2	x2	x2	x2	x2	x1
MT-1502-10S	x4	x4	x4	x4	x4	x2
MT-2001-10S	x2	x2	x2	x2	x2	x1
MT-2002-10S	x4	x4	x4	x4	x4	x2
MT-2003-10S	x6	x6	x6	x6	x6	x3



CAP ATTACHMENTS INCLUDED

With the included cap attachments, you can embroider a variety of cap styles. Each MT-10S comes with a hoop station, cap rings and cap driver(s) for all of your cap embroidery needs.

Models	Cap Rings  Cap rings snap into hoop station to prepare machine for cap embroidery	Hoop Station  Hoop station provides stability for fast and easy cap hooping	Cap Driver  Cap driver snaps into embroidery machine's bracket holder for hoops
MT-1501-10S	x2	x1	x1
MT-1502-10S	x4	x1	x2
MT-2001-10S	x2	x1	x1
MT-2002-10S	x4	x1	x2
MT-2003-10S	x6	x1	x3

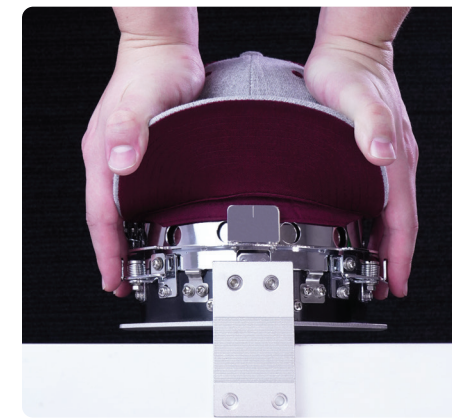

EXTENDED EMBROIDERY AREA

MAXIMIZE YOUR EMBROIDERY AREA TO CREATE LARGE, DETAILED DESIGNS WITH EASE

The MT-10S extended table and sash frame is the perfect way to increase your business offerings by embroidering on oversized items such as drapery, blankets, banners, mattress borders, wedding dresses, quilt covers and much more.

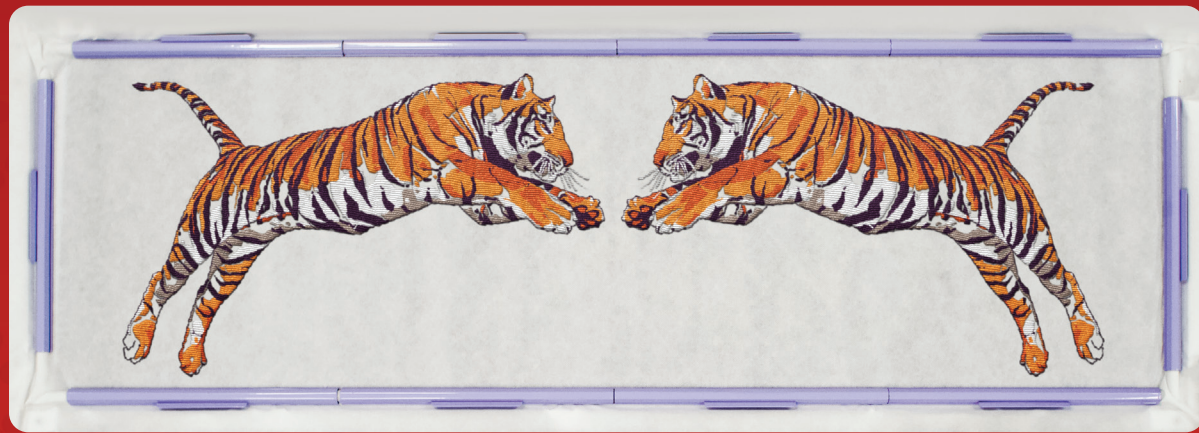

Sash frame for single-head extended table MT-4814-1



Frame Models	Embroidery Area	Machines
MT-2214	540 x 365 mm (21.3 x 14.4 in) *U.S. only. Optional worldwide	MT-1501-10S / MT-2001-10S
MT-4814-1	1230 x 365 mm (48.4 x 14.4 in) *Optional	MT-1501-10S / MT-2001-10S
MT-2214-2	1230 x 365 mm (48.4 x 14.4 in) *U.S. only. Optional worldwide	MT-1502-10S / MT-2002-10S
MT-2214-3	1820 x 365 mm (71.7 x 14.4 in) *Included worldwide	MT-2003-8S



OPTIONAL ADD-ONS

BROADEN YOUR POSSIBILITIES WITH THESE AFFORDABLE AND EASY-TO-USE ADD-ONS!

These attachments make hooping and adding embroidery effects a breeze. Embellish your designs with sequins, boring or cording, or use specialty hoops to gain more control over your embroidery projects and enhance your production capabilities.

DEVICES

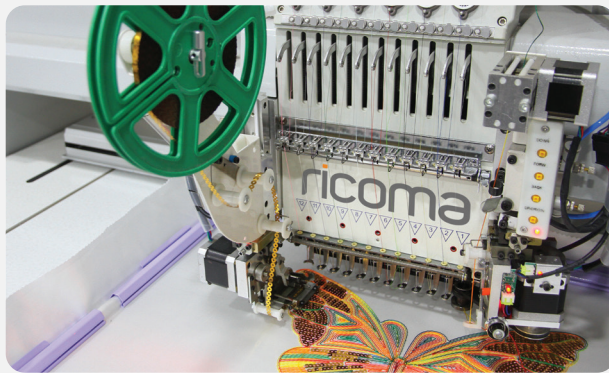

Sequin Device (SQ-E)

Attach the optional sequin device to your embroidery machine to add a pop of sparkle to your designs.



Bead Device

Explore your creativity to include intricate bead work with the optional bead device.



Cording Device (CD-E)

Easily create an embroidery effect with the cording device, which lays cord on fabric and attaches the cord with transparent zigzag stitches.

**For a list of all compatible devices, contact a product specialist.*

ACCESSORIES

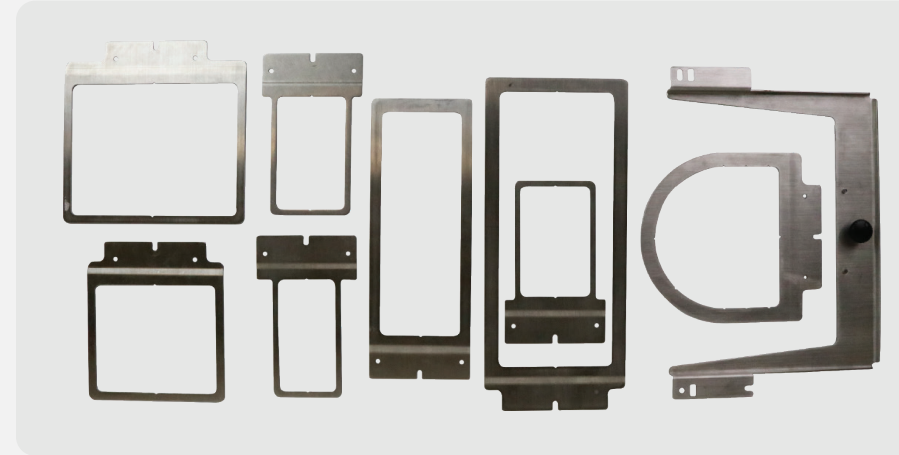

8-in-1 Hoopset (8D-2)

Includes 8 frames that make embroidering easier than ever before. It's designed for hard-to-hoop items such as shirt pockets, socks, backs of caps, shirt sleeves, collar tips and more.



Belt Hoop (BH-2)

With an 8-inch x 4-inch embroidery area, the belt hoop provides ample room for embroidery on belts and straps.



Mighty Hoop Magnetic Hoops

This magnetic hoop is popular among professional embroiderers because it makes hooping any type of flat garment easier than ever.



Boring Needle

This specifically designed needle creates intricate embroidery by piercing the fabric, cutting it into various shapes, and leaving holes in the item.

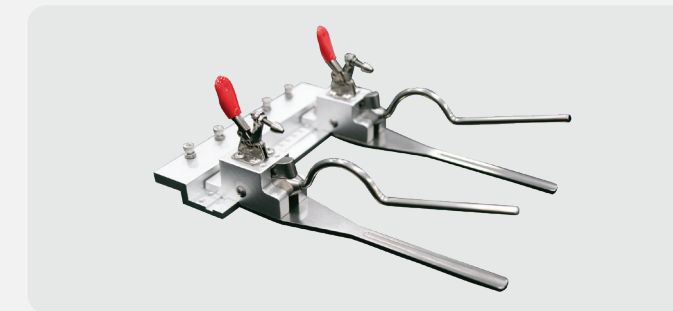

Robot Frame (RF-M)

Firmly clamp and embroider difficult-to-hoop items like shoes, purses, bags and more with the robot frame.

**For a list of all compatible devices, contact a product specialist.*



Laser Positioning Device (LD)

This easy-to-install tracing tool lets you quickly determine if the design is within the hoop range.

TWO-HEAD SOLUTIONS

DOUBLE YOUR PRODUCTION CAPACITY

Increase your ability to produce high-quality embroidery and take on batch orders like a pro. Our two-head embroidery machines will cut your production time in half on caps, bags, towels, jackets and more!



STARTUP PACKAGE

EQUIPPED WITH ALL THE ATTACHMENTS TO GET STARTED RIGHT AWAY

Get started with everything you need to succeed without spending thousands on additional accessories. Your MT-10S comes equipped with a variety of hoops, caps attachments, and other embroidery essentials. This all-inclusive package is ideal for startups or established apparel businesses that want to expand their embroidery capabilities.

PACKAGE



Heavy Duty Steel Stand

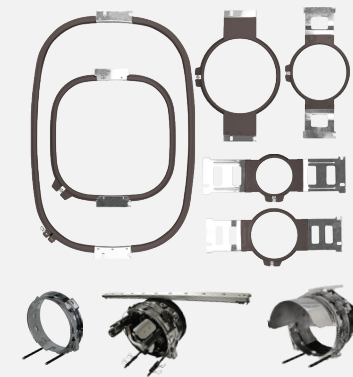

A Variety of Hoops and Cap Attachments

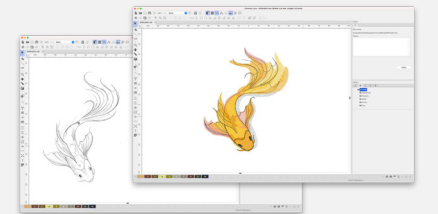

Chroma Digitizing Software



Madeira Starter Kit

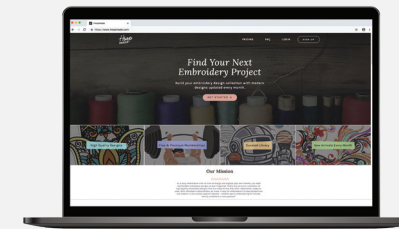

Three-Month Subscription To Hoopmade



Training and Lifetime Support 7 Days a Week and After Hours

**The above-mentioned items are included in the startup package only when purchased directly from our U.S. Headquarters – Ricoma International Corporation.*



THINK BEYOND



facebook.com/ricomahq



youtube.com/ricomamiami



pinterest.com/ricomahq



instagram.com/ricomahq



twitter.com/ricomahq

Ricoma Headquarters in USA

Ricoma International Corporation

11555 NW 124 Street, Miami, FL 33178, USA

TEL: (305) 418-4421 | FAX: (305) 418-5036

Toll Free: 1-888-292-6282

Website: www.ricoma.com | Email: info@ricoma.com

Ricoma Factory in China

Ricoma (Huizhou) Co., Ltd.

Ricoma Science & Technology Industrial Park, No.1 Hongtong Road,

Dayawan West District 516083, Huizhou, Guangdong, China

TEL: +86 752 5366 999 | Toll Free: 400-900-2939

Website: www.ricoma.cn | Email: info@ricoma.cn

Website: www.ricoma.com.cn | QQ: 3546416573 | WeChat: 18169980181