

# SWIFT

TC-10S

COMMERCIAL EMBROIDERY MACHINE  
WITH INTUITIVE 10.1" HIGH-DEFINITION TRUE-COLOR TOUCH SCREEN



# MAIN FEATURES

The TC-10S has a wide range of capabilities and functions for commercial use but is still sleek and compact enough for at-home businesses.

- Suitable for embroidery on flats, caps, finished garments and more!
- Perfect for small and established businesses alike
- High-Definition True-Color 10.1-inch LCD Touch Screen
- Maximum embroidery area: 520 x 350 mm (20.5 x 13.8 in)
- Maximum speed: 1200 spm
- Large memory capacity: 100 million stitches or 1000 designs
- Machine reads multiple design formats such as DST, DSB, TBF and more
- Wide angle cap system: 270°
- Smaller sewing arm greatly improves the performance of cap embroidery and embroidery on small items
- Heavy-duty steel stand with wheels for both stability and mobility
- Multiple hoop sizes for a variety of embroidery needs
- Automatic color change
- Automatic thread trimmer
- Reinforced upper thread clamp to ensure stable trimming
- Thread break detection
- Networkable – USB input or direct transmission from PC via LAN port
- Easily add appliqué, sequin or cording
- Frame offset and frame outlining are available for easy appliqué embroidery
- Automatic memory retention
- Adjustable control panel positioning for better visibility and comfort
- Built-in button from 172° to 196° under manual color change mode to help with machine maintenance
- Recessed USB port to protect USB flash drive
- Multiple languages: English, Chinese, Spanish
- Servo motor 150W – lowest power consumption in the industry!
- Built-in universal power supply, 110V/60Hz and 220V/50Hz self-adaptable worldwide
- DC36V micro-step motor for X & Y axis driving ensures low noise and less vibration
- Compatible with optional laser tracing device
- Front LED lamp provides better visibility and protection for eyes against strong light during threading
- Environmentally friendly packaging
- Perfect for mass production of patches
- Slim machine width allows for easy entry through standard-sized doors



FRAME OFFSET AND FRAME OUTLINING



AUTOMATIC COLOR CHANGE



10.1" USER-FRIENDLY TOUCH PANEL



270° WIDE ANGLE CAP SYSTEM



THREAD BREAK DETECTION

# SINGLE-HEAD SOLUTIONS

## TECHNICAL SPECIFICATIONS

|                                 |   |
|---------------------------------|---|
| Machine Name                    | TC-10S  |
| Models                          | TC-1201-10S/TC-1501-10S/TC-2001-10S               |
| Panel                           | High-Definition True-Color 10.1" LCD Touch Screen |
| Heads                           | 1   |
| Needles                         | 15/20   |
| Machine Size With Stand (L*W*H) | 750 x 740 x 1685 mm (29.5 x 29.1 x 66.3 in)       |
| Net Weight                      | 120 kg (264.6 lbs)                                |
| Gross Weight                    | 160 kg (352.7 lbs)                                |
| Embroidery Area                 | 520 x 350 mm (20.5 x 13.8 in)                     |
| Cap Embroidery Area             | 270°  |
| Maximum Speed                   | 1200 spm  |
| Voltage                         | 90-240 v  |
| Power Consumption               | 0.2 kw  |
| Memory Capacity                 | 100 million stitches or 1000 designs              |

# INTELLIGENT TECHNOLOGY

## HIGH-TECH FEATURES TO EXPAND YOUR CAPABILITIES!



# FROM PASSION TO PROFIT

## THE PERFECT EMBROIDERY MACHINES FOR ENTREPRENEURS

The TC-10S are the industry's best commercial embroidery machines for entrepreneurs who are ready to profit from their custom creations. Whether it's a side hustle, full-time start-up or a growing business, the TC-10S delivers high-quality, high-speed, and high-precision embroidery on a wide variety of garments.

Equipped with its groundbreaking **Simplexity** technology, made possible by the **latest 10.1-inch control panel**, the TC-10S is specially designed to make machine embroidery incredibly simple and easy to learn.

# Simplexity TECHNOLOGY

## INTRODUCING THE NEWEST 10.1-INCH TOUCHSCREEN PANEL

The 10S model boasts an impressive 10.1-inch touchscreen panel that is intuitive and user-friendly. You'll enjoy the convenience of its **simple user interface** which makes it incredibly easy to navigate the machine's numerous functions and tools.

Powered by its innovative **Simplexity** technology, the 10S panel has a built-in **Tool Tips function** and a **help center** to provide an explanation of the selected option on the screen. Knowing what a specific tool does is an excellent way to quickly learn about your machine's capabilities, prevent user errors, and create an efficient workflow.

Additionally, the new **maintenance alert feature** does the thinking for you to remind you when basic maintenance needs to be done on your machine to reduce the learning curve and help your machine run smoothly.

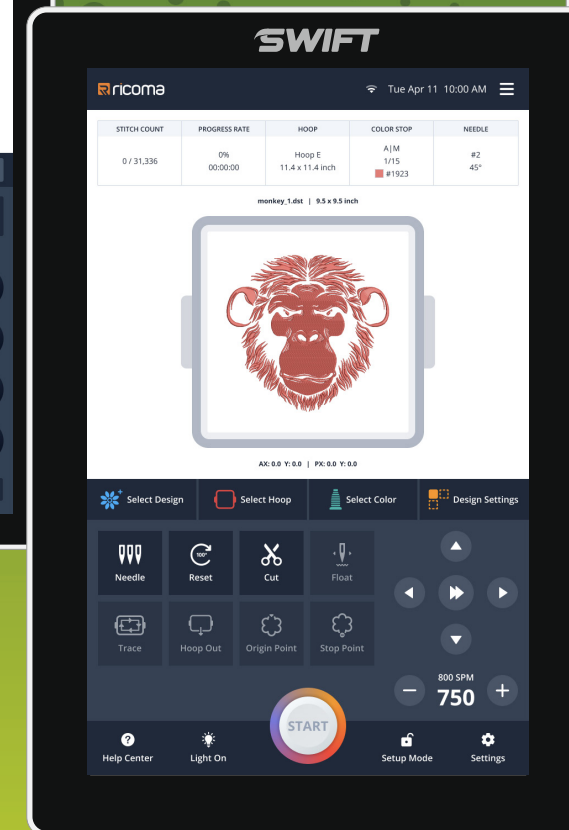
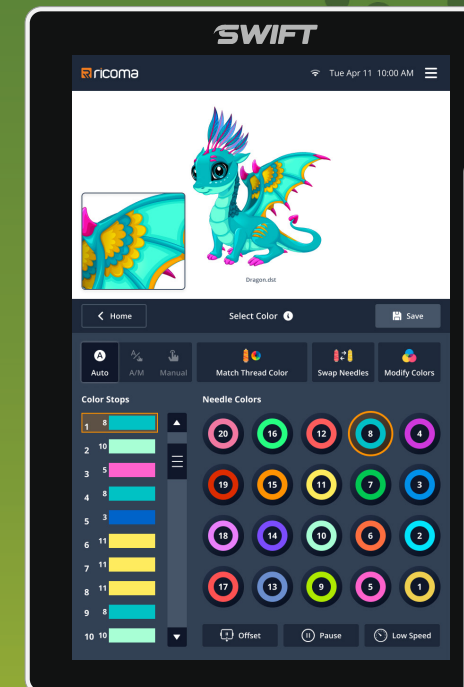

# PANEL FEATURES

## TECHNICAL SPECIFICATIONS

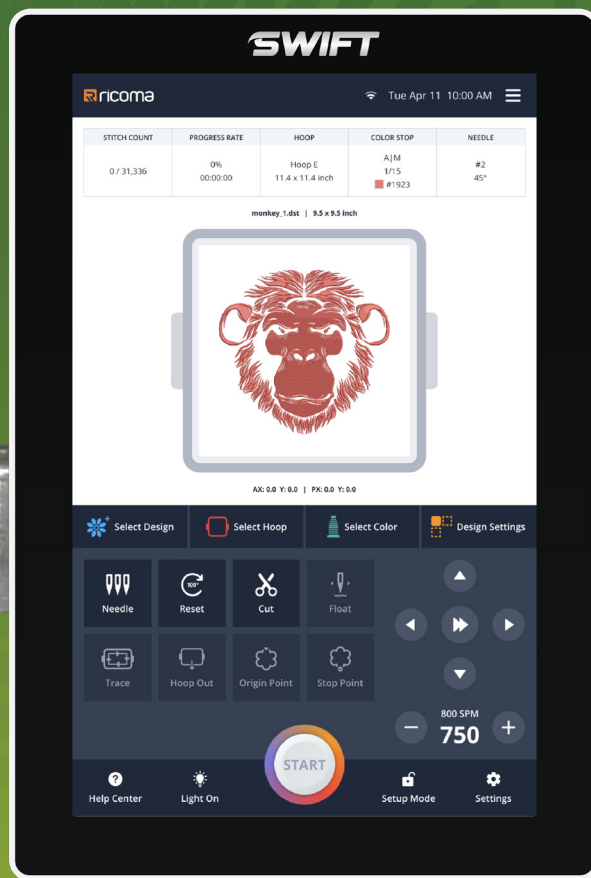

- Large memory capacity: 100 million stitches or 1000 designs with a maximum of 1000 automatic color changes

- Machine reads multiple design formats such as DST, DSB, TBF and more

- Easy to operate

- Full touch capacitive screen supports multi-touch and sliding screen operation

- Frame offset and frame outlining are available for easy appliqué embroidery

- Preset hoop parameters, which are designed to avoid hitting hoop frames

- Networkable – USB input or direct transmission from PC via LAN port

- Automatic color change

- Simplify machine maintenance with built-in 172-degree and 196-degree keys

- Generate new designs by adjusting the parameters and dimensions of pre-existing patterns

- Automatic thread trimmer

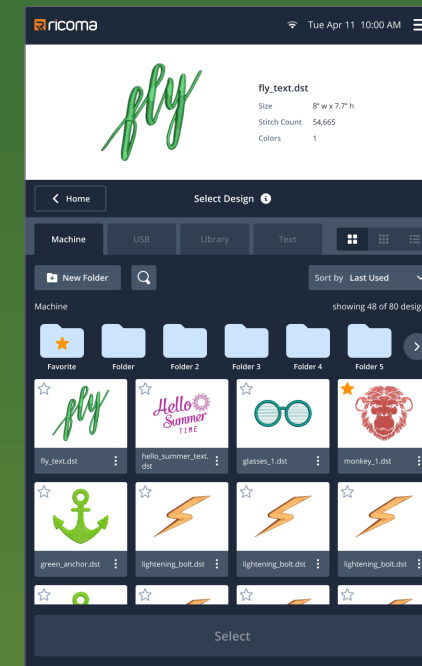

Select Design

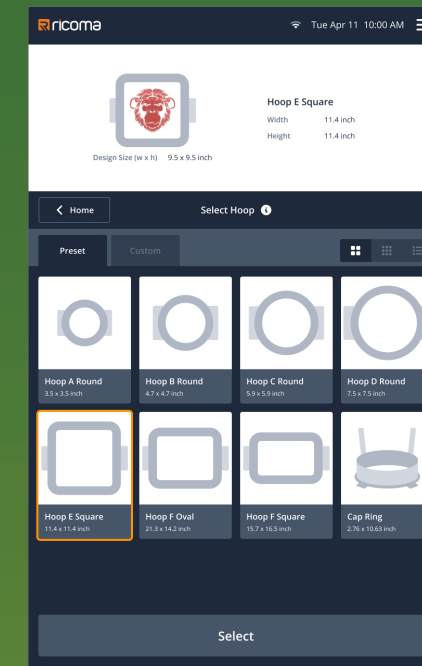

Select Hoop

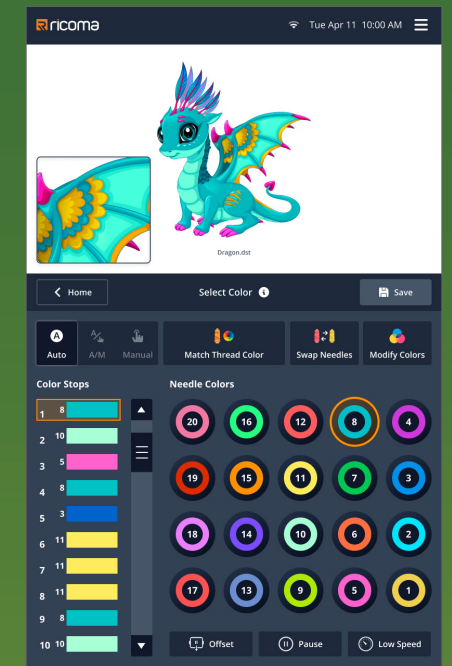

Select Color

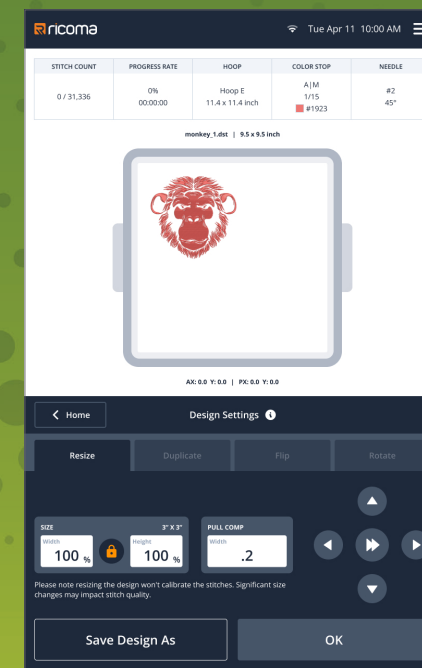

Design Settings

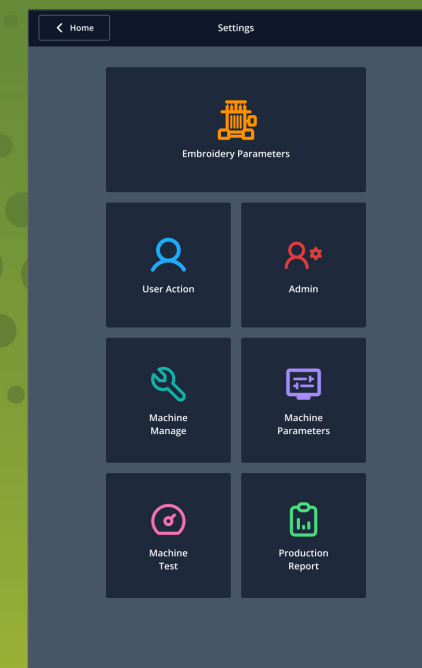

Machine Settings

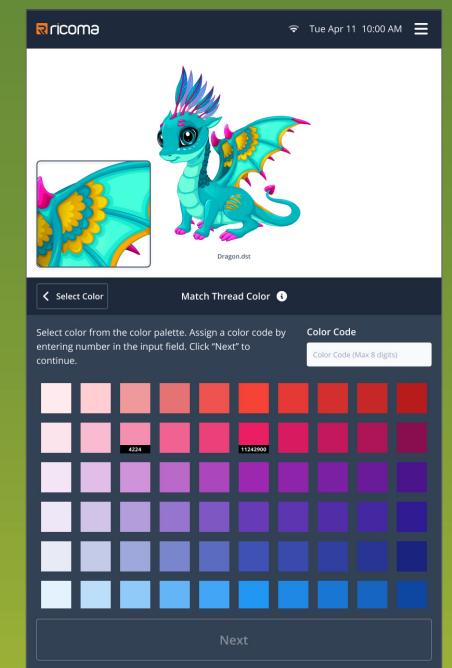

Match Thread Colors

# PANEL FEATURES (CONT'D)

- Embroidery starting point saved to the machine's memory to increase efficiency

- Built-in factory mode, standardizing outgoing quality control process

- Easily access 24 different fonts to create custom words and phrases

- Machine parameters can be exported and imported for easy maintenance

- Repeatedly embroider the same design multiple times to increase productivity with repetition embroidery, which can also be used with cyclic embroidery

- Built-in screenshot function

- Cyclic embroidery function automatically returns the machine to the origin point and starts the same embroidery process again

- Optional laser trace device available

- Computer, encoder and main shaft testing are available to make maintenance and debugging more convenient

- Built-in file management system

- Automatic speed adjustment from one needle to the next

- Import & outport embroidery parameter

- Export system log function

- Machine maintenance reminder

- Customize distinct alert sounds for different fault alarms to easily identify issues

- Change the background on the hoop in the panel to ensure the design stands out

- Dynamic display of color sequence steps for easy color sequence setting

- Design management supports sorting and searching functions

- Screen saver function: adjust screen saver time, picture and display brightness

- Support switching between metric and imperial units

- Choose between light mode and dark mode settings depending on your preference

- Combine different embroidery patterns

- Built-in help function

- Multiple languages: English, Chinese, Spanish

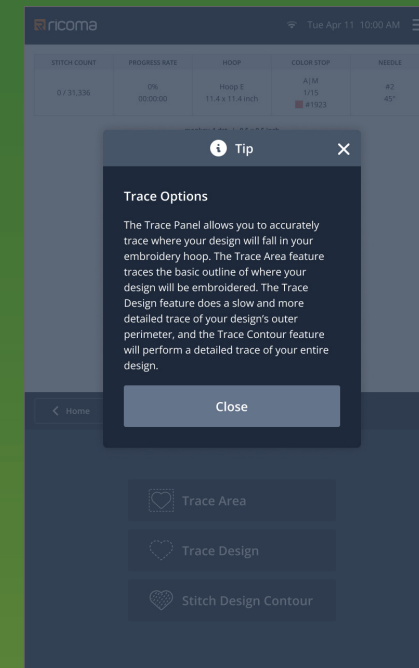

Tool Tips

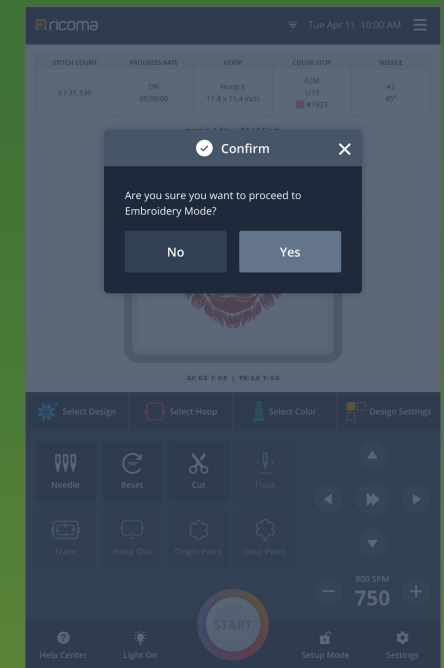

Confirmation Pop-ups

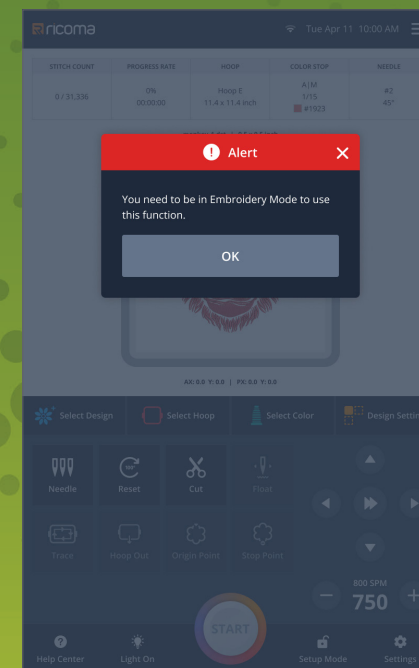

Pop-up Alerts

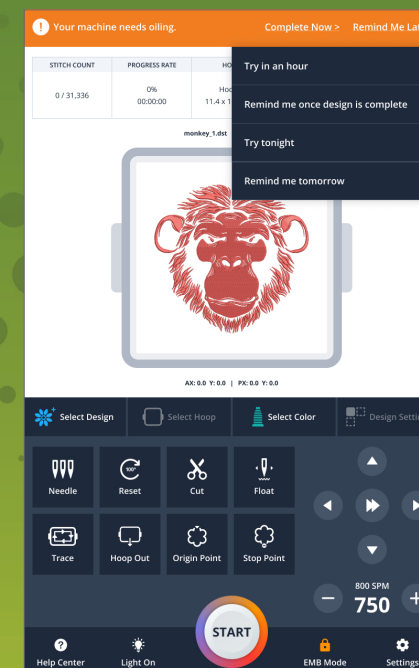

Machine Maintenance Reminders

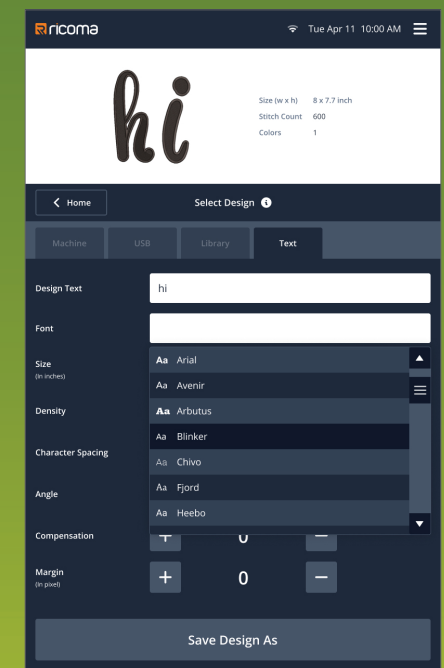







Multiple Fonts Available

# HOOPS & CAP ATTACHMENTS

## A RANGE OF HOOP SIZES AND SASH FRAMES TO KICKSTART ANY EMBROIDERY SHOP

The TC-10S comes with everything you need to embroider just about any item so that you can take on a range of projects. Each machine includes a variety of hoop sizes for embroidering small designs like left-chest logos and large designs on bags, towels and more.

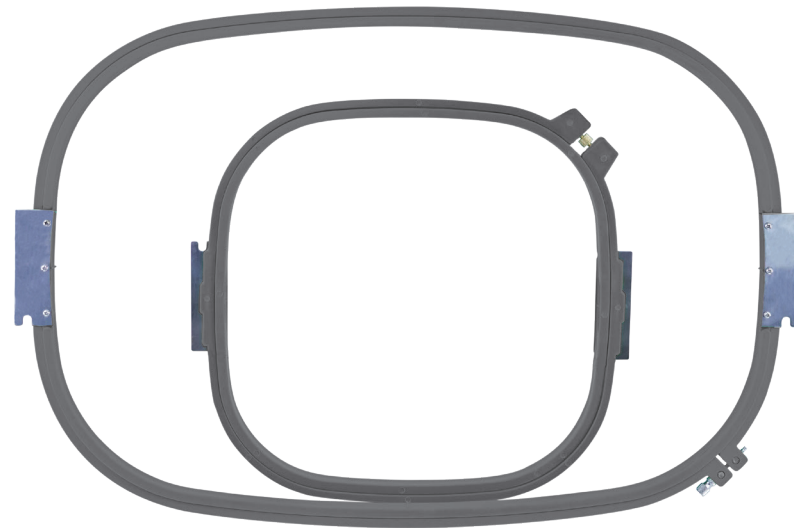
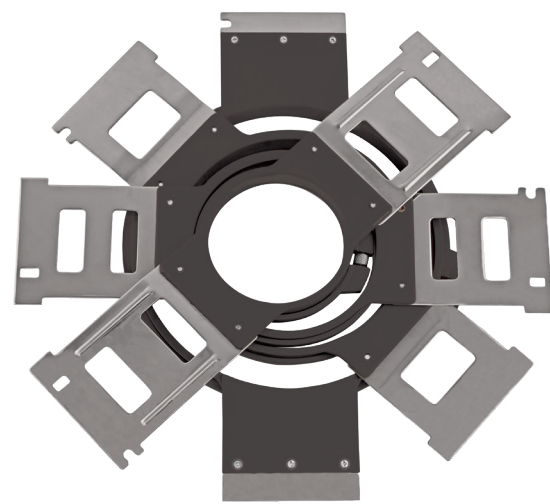

|   |    |                                  |
|---|----|----------------------------------|
|    | x2 | 90 x 90 mm<br>(3.5 x 3.5 in)     |
|    | x2 | 120 x 120 mm<br>(4.7 x 4.7 in)   |
|    | x2 | 150 x 150 mm<br>(5.9 x 5.9 in)   |
|    | x2 | 190 x 190 mm<br>(7.5 x 7.5 in)   |
|   | x2 | 290 x 290 mm<br>(11.4 x 11.4 in) |
|  | x1 | 540 x 360 mm<br>(21.3 x 14.2 in) |

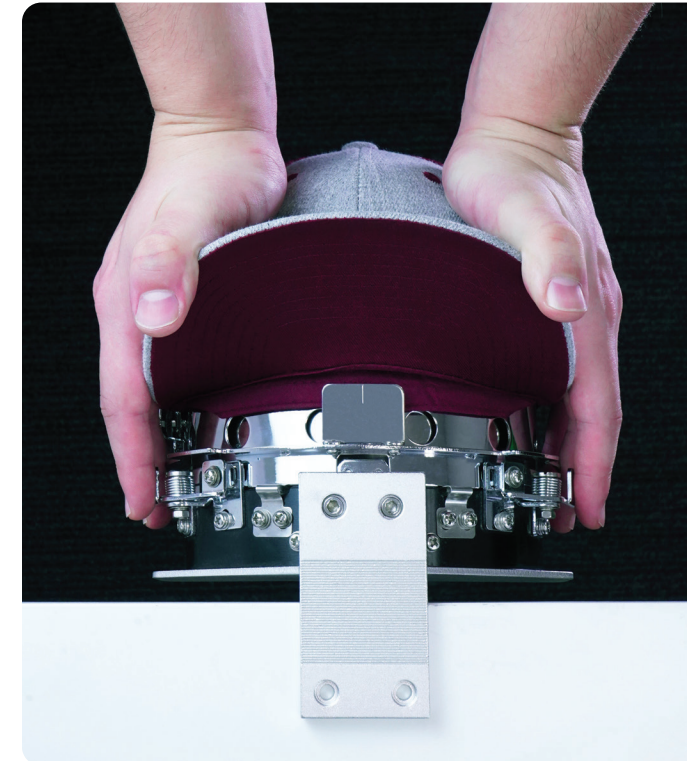

## CAP ATTACHMENTS INCLUDED

With the included cap attachments, you can embroider a variety of cap styles. Each TC-10S machine comes with a hoop station, cap rings and cap driver(s) for all of your cap embroidery needs.



|   |    |  |
|---|----|--|
|  | x2 | Cap rings snap into the hoop station to prepare the machine for cap embroidery |
|  | x1 | Hoop station provides stability for fast and easy cap hooping                  |
|  | x1 | Cap driver snaps into the embroidery machine's bracket holder for hoops        |

# EXTENDED EMBROIDERY AREA

## EXTEND YOUR EMBROIDERY AREA TO CREATE LARGE, DETAILED DESIGNS WITH EASE

The extended table is the perfect aide for embroidery on oversized items such as drapery, blankets, banners, mattress borders, wedding dresses, quilt covers and much more. The additional space will help you expand your embroidery shop and attract new customers.

| Frame Models | Embroidery Area                             | Machines |
|--------------|---|----------|
| W-2214       | 540 x 365 mm (21.3 x 14.4 in)<br>*Included  | TC-10S   |
| EW-4814-2    | 1230 x 365 mm (48.4 x 14.4 in)<br>*Optional | TC-10S   |





# OPTIONAL ADD-ONS

## BROADEN YOUR POSSIBILITIES WITH THESE AFFORDABLE AND EASY-TO-USE ADD-ONS!

These attachments make hooping and adding embroidery effects a breeze. Embellish your designs with sequins, boring or cording, or use specialty hoops to gain more control over your embroidery projects.

### DEVICES



#### Sequin Device (SQ-E)

Attach the optional sequin device to your embroidery machine to add a pop of sparkle to your designs.

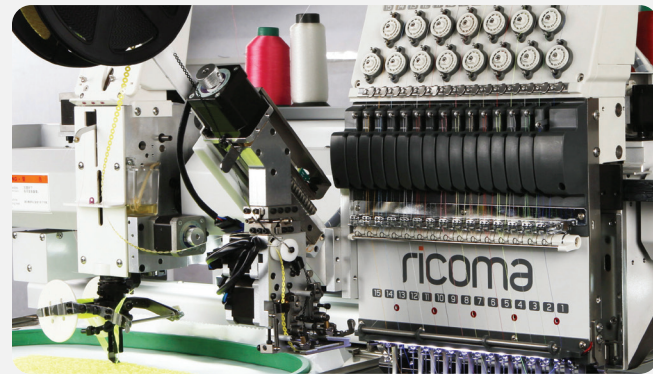

#### Cording Device (CD-E)

Easily create an embroidery effect with the cording device, which lays cord on fabric and attaches the cord with transparent zigzag



#### Laser Cutting Device

High powered laser beam to cleanly cut a specific design on materials such as patches, labels, and many other fabric decorations. All these can be achieved with high precision and speed.



#### Twin Sequin Device (2SQ-E)

Double your sequin capabilities with double the color and coil with the optional twin sequin device.

*\*For a list of all compatible devices, contact a product specialist.*

### ACCESSORIES

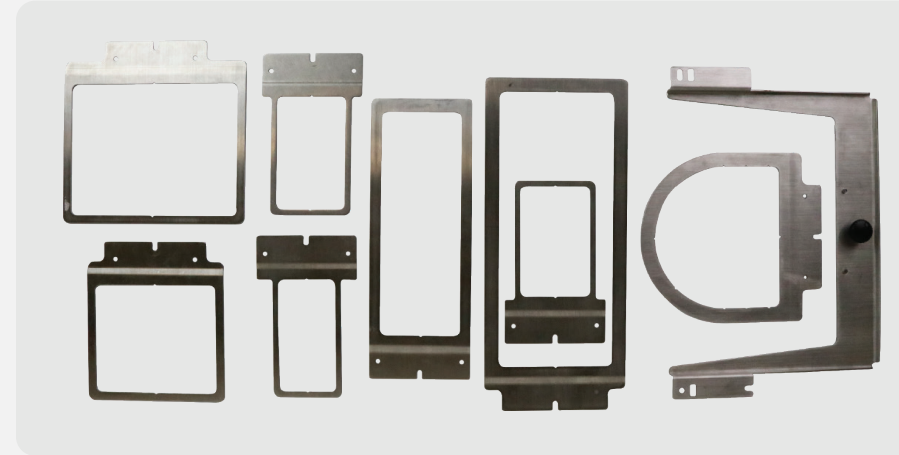

#### 8-in-1 Hoopset (8D-2)

Includes 8 frames that make embroidering easier than ever before. It's designed for hard-to-hoop items such as shirt pockets, socks, backs of caps, shirt sleeves, collar tips and more.



#### Belt Hoop (BH-2)

With an 8-inch x 4-inch embroidery area, the belt hoop provides ample room for embroidery on belts and straps.



#### Mighty Hoop Magnetic Hoops

This magnetic hoop is popular among professional embroiderers because it makes hooping any type of flat garment easier than ever.



#### Boring Needle

This specifically designed needle creates intricate embroidery by piercing the fabric, cutting it into various shapes, and leaving holes in the item.

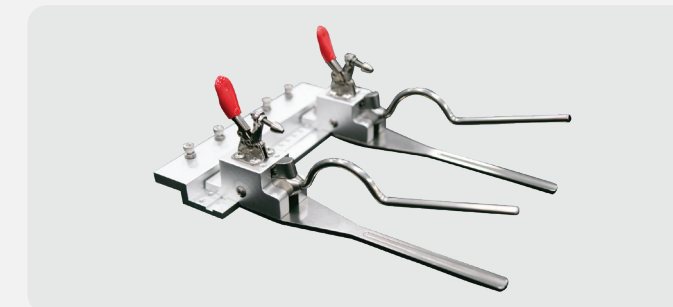

#### Robot Frame (RF-M)

Firmly clamp and embroider difficult-to-hoop items like shoes, purses, bags and more with the robot frame.



#### Laser Positioning Device (LD)

This easy-to-install tracing tool lets you quickly determine if the design is within the hoop range.

*\*For a list of all compatible devices, contact a product specialist.*

# TAILORED TO FIT YOUR NEEDS

## 15, & 20-NEEDLE SOLUTIONS

Available in 15, or 20 needles, the TC SERIES 10S are fast and efficient machines designed to meet the needs of decorators of all experience levels. Ideal for both new and established apparel businesses alike, this versatile series is for anyone that wants to increase their ability to produce high-quality embroidery.



# STARTUP PACKAGE

## EQUIPPED WITH ALL THE ATTACHMENTS TO GET STARTED RIGHT AWAY

Get started with everything you need to succeed without spending thousands on additional accessories. Your TC-10S comes equipped with a variety of hoops, caps attachments, and other embroidery essentials. This all-inclusive package is ideal for startups or established apparel businesses that want to expand their embroidery capabilities.

### PACKAGE



Heavy Duty Steel Stand

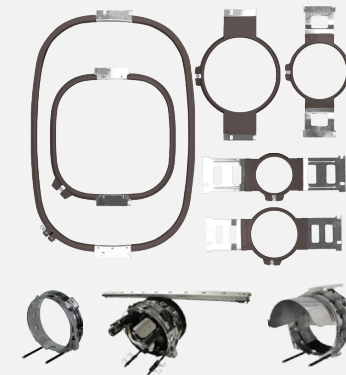

A Variety of Hoops and Cap Attachments

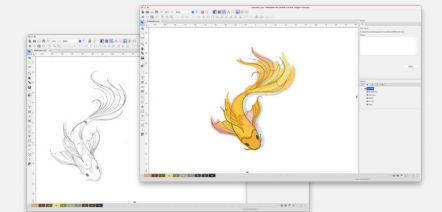

Chroma Digitizing Software



Madeira Starter Kit

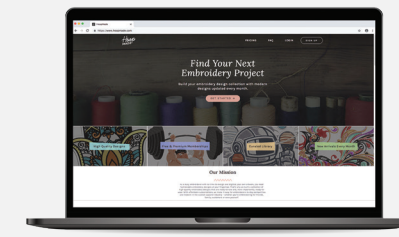

Three-Month Subscription To Hoopmade



Training and Lifetime Support 7 Days a Week and After Hours

*\*The above-mentioned items are included in the startup package only when purchased directly from our U.S. Headquarters – Ricoma International Corporation.*



THINK BEYOND



[facebook.com/ricomahq](https://facebook.com/ricomahq)



[youtube.com/ricomamiami](https://youtube.com/ricomamiami)



[pinterest.com/ricomahq](https://pinterest.com/ricomahq)



[instagram.com/ricomahq](https://instagram.com/ricomahq)



[twitter.com/ricomahq](https://twitter.com/ricomahq)

---

**Ricoma Headquarters in USA**

**Ricoma International Corporation**

11555 NW 124 Street, Miami, FL 33178, USA

TEL: (305) 418-4421 | FAX: (305) 418-5036

Toll Free: 1-888-292-6282

Website: [www.ricoma.com](http://www.ricoma.com) | Email: [info@ricoma.com](mailto:info@ricoma.com)

**Ricoma Factory in China**

**Ricoma (Huizhou) Co., Ltd.**

Ricoma Science & Technology Industrial Park, No.1 Hongtong Road,

Dayawan West District 516083, Huizhou, Guangdong, China

TEL: +86 752 5366 999 | Toll Free: 400-900-2939

Website: [www.ricoma.cn](http://www.ricoma.cn) | Email: [info@ricoma.cn](mailto:info@ricoma.cn)

Website: [www.ricoma.com.cn](http://www.ricoma.com.cn) | QQ: 3546416573 | WeChat: 18169980181