

SEIKO

PARTS LIST
パーツリスト

H-2BL-AE-1

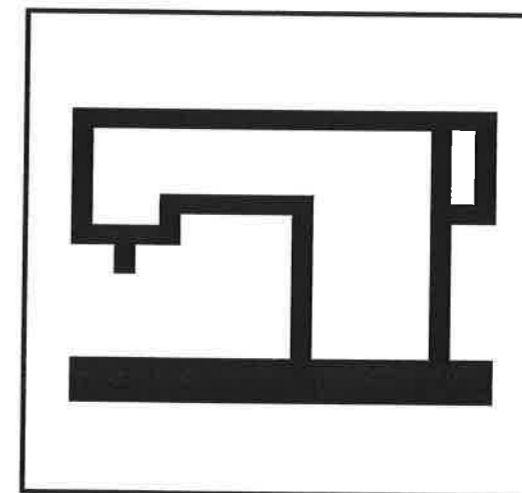

SEIKO SEWING MACHINE CO.,LTD.

SEIKO SEWING MACHINE CO., LTD.

2-13-6 Sakaecho, Funabashi-shi Chiba Prefecture,
273-0018, Japan

TEL: 81-47-420-3561 (Overseas dept.)

FAX: 81-47-420-3560

E-mail: export@seiko-sewing.co.jp

<http://www.seiko-sewing.co.jp/>

セイコーミシン株式会社

〒273-0018 千葉県船橋市栄町2-13-6

TEL: 047-420-3561, IP電話: 050-3535-3491

FAX: 047-420-3560

E-mail: eigyo@seiko-sewing.co.jp

(国内営業)

Parts No. PB02610 (0616)

Rev. 1

付属品関係/Accessories

No	部品番号 PARTS No	員数 QTY	品名	DESCRIPTION
1	35254	1	糸立てセット	THREAD UNWINDER COMP.
2	11193	1	油 (大)	OIL TANK
3	08125	1	油差し	POLY OILER
4	18034	3	ボビン	BOBBIN
5	24585	1	糸巻きセット	BOBBIN WINDER COMPLETE
6	10734-24	2	木ねじ	WOOD SCREW
7	27186	2	平ワッシャー	PLAIN WASHER
8	24586C	1	ベルトガード (組)	BELT GUARD COMPLETE
9	24587	2	上カバー本体止ねじ	SCREW, M4X0.7 L=10
10	24588	2	ベルトガード本体止ねじ	SCREW, M5X0.8 L=12
11	24589	4	上カバー止ねじ	SCREW, M4X0.7 L=8
12	24590	4	平ワッシャー	PLAIN WASHER
13	24591	2	木ねじ	WOOD SCREW
14	24592	2	平ワッシャー	PLAIN WASHER
15	24593	2	頭部敷きゴム (F)	HEAD CUSHION, F
16	24594	2	頭部敷きゴム (B)	HEAD CUSHION, B
17	08132-A	1	部品袋	ACCESSORY BAG
18	08124	1	ビニールカバー	VINYL COVER
19	N0123	3	針 DPX17 #23	NEEDLE DPX17 (#23)
20	24595	2	ヒンジ受けゴム	RUBBER CUSHION
21	06055	4	ヒンジ受け止釘	NAIL
22	24596	2	ヒンジ	HEAD HINGE
23	08118C	1	ドライバー (4点組)	SCREW DRIVER COMPLETE
----- オプション部品 -----				----- OPTIONAL PARTS -----
24	24807	1	検出器アダプター	SYNCHRONIZER ADAPTOR
25	24808	1	検出器支え棒	SYNCHRONIZER SUPPORT
26	37102	2	ナット	NUT, M6X1

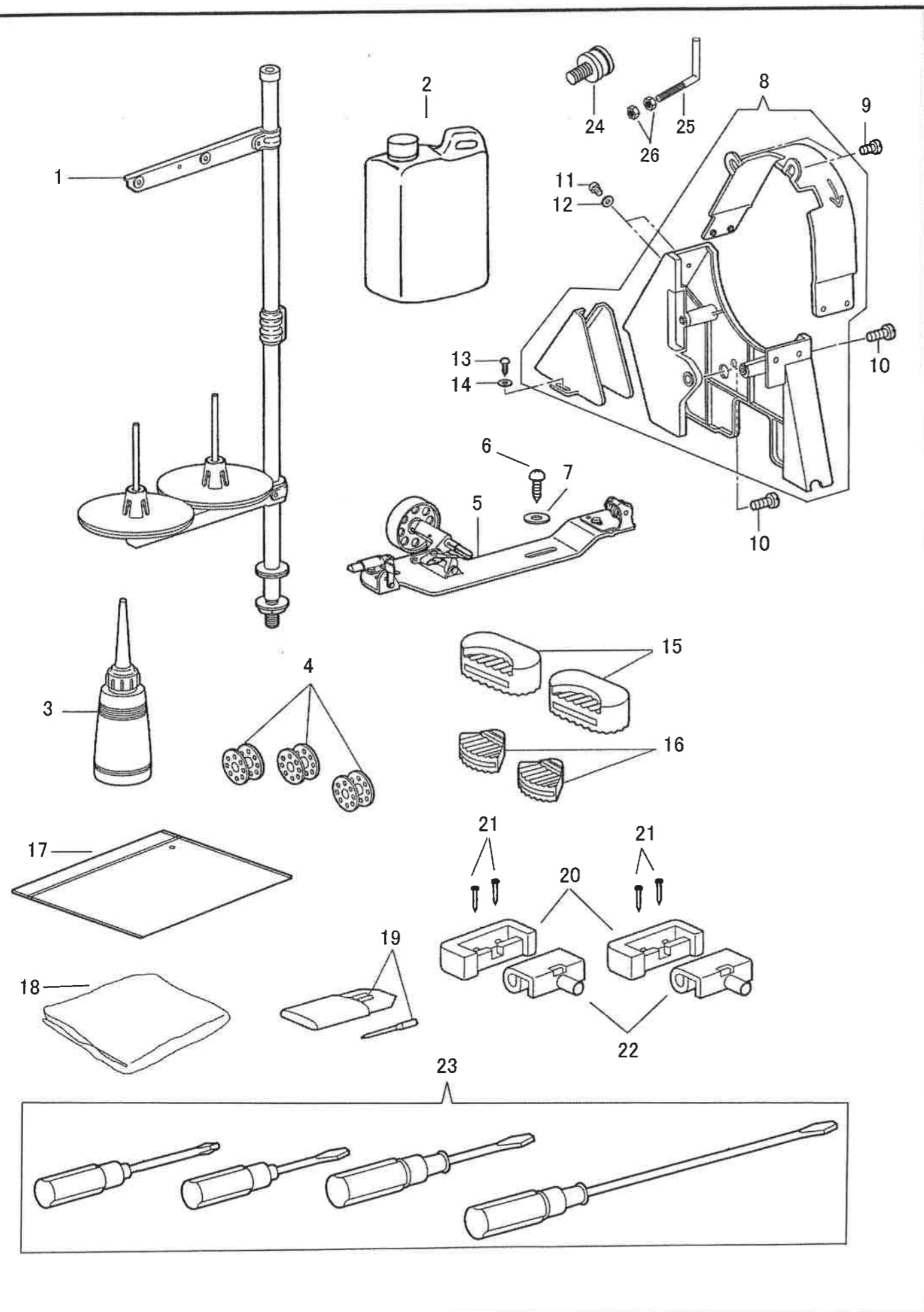

	Page
主体関係 Machine body	1, 2
針棒・天秤関係 Needle bar and thread take-up mechanism	3, 4
押え関係 Presser foot mechanism	5, 6
上送り関係 Upper feed mechanism	7, 8
下送り関係 Lower feed mechanism	9, 10
送り調節関係 Feed regulating mechanism	11, 12
カマ関係 Rotary hook mechanism	13, 14
給油潤滑関係 Lubrication	15, 16
糸通し関係 Threading mechanism	17, 18
付属品関係 Accessories	19, 20

主体関係/Machine body

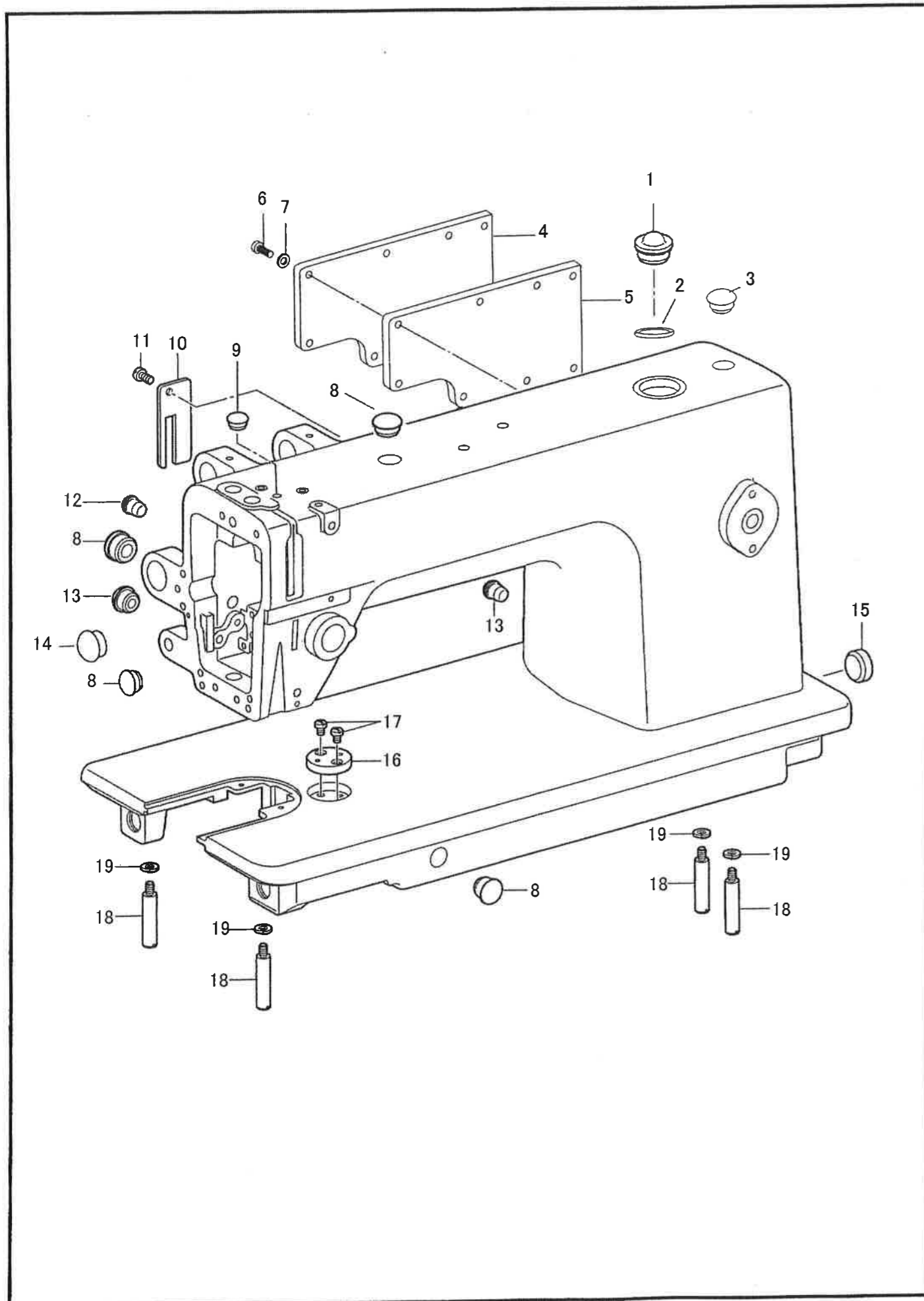

糸通し関係/Threading mechanism

No	部品番号 PARTS No	員数 QTY	品名	DESCRIPTION
1	24581	1	面板	FACE PLATE
2	24411	3	面板締めねじ	SCREW, SM11/64X40 L=20
3	24412	1	アーム糸案内	THREAD GUIDE
4	24413	1	アーム糸案内D	THREAD GUIDE, D
5	24414	3	アーム糸案内止めねじ	SCREW, SM9/64X40 L=6
6	24415	1	糸案内組	THREAD GUIDE ASSY
6-1	24416	1	糸案内	THREAD GUIDE
6-2	24417	1	糸案内調子棒	PRE-TENSION STUD
6-3	24418	2	糸案内皿	DISC, THREAD GUIDE
6-4	24419	1	プレテンションバネ	SPRING
6-5	24420	1	糸案内調子ねじ	ADJUSTING SCREW
7	24582	1	糸案内組取付ねじ	SET SCREW
8	24492	1	アーム糸案内B	THREAD GUIDE, B
10	24430	1	糸調子棒組	THREAD TENSION BRACKET ASSY
10-1	24431	1	糸調子棒	TENSION STUD
10-2	24432	1	糸調子ナット	TENSION NUT
10-3	24433	1	糸調子バネ	TENSION SPRING
10-4	24434	1	糸調子皿押え	DISC PRESSER
10-5	24435	2	糸調子皿	DISC, TENSION
10-6	24436	1	糸取りバネ	SPRING
10-7	24437	1	糸調子棒台	THREAD TENSION BRACKET
10-8	24438	1	糸調子棒止めねじ	SET SCREW, SM9/64X40 L=6
10-9	24439	1	糸緩めピン	PIN
10-10	24440	1	ローレットストッパー	STOPPER
10-11	24441	1	Oリング	O RING
11	24079	1	止めねじ	SET SCREW, SM15/64X28 L=8
12	24583	1	天秤カバー	THREAD TAKE-UP LEVER COVER
13	24584	1	締めねじ	SCREW, SM11/64X40 L=5.5
14	24445	1	糸掛	THREAD RETAINER
15	24446	1	糸掛締めねじ	SCREW, SM11/64X40 L=8

糸通し関係/ Threading mechanism

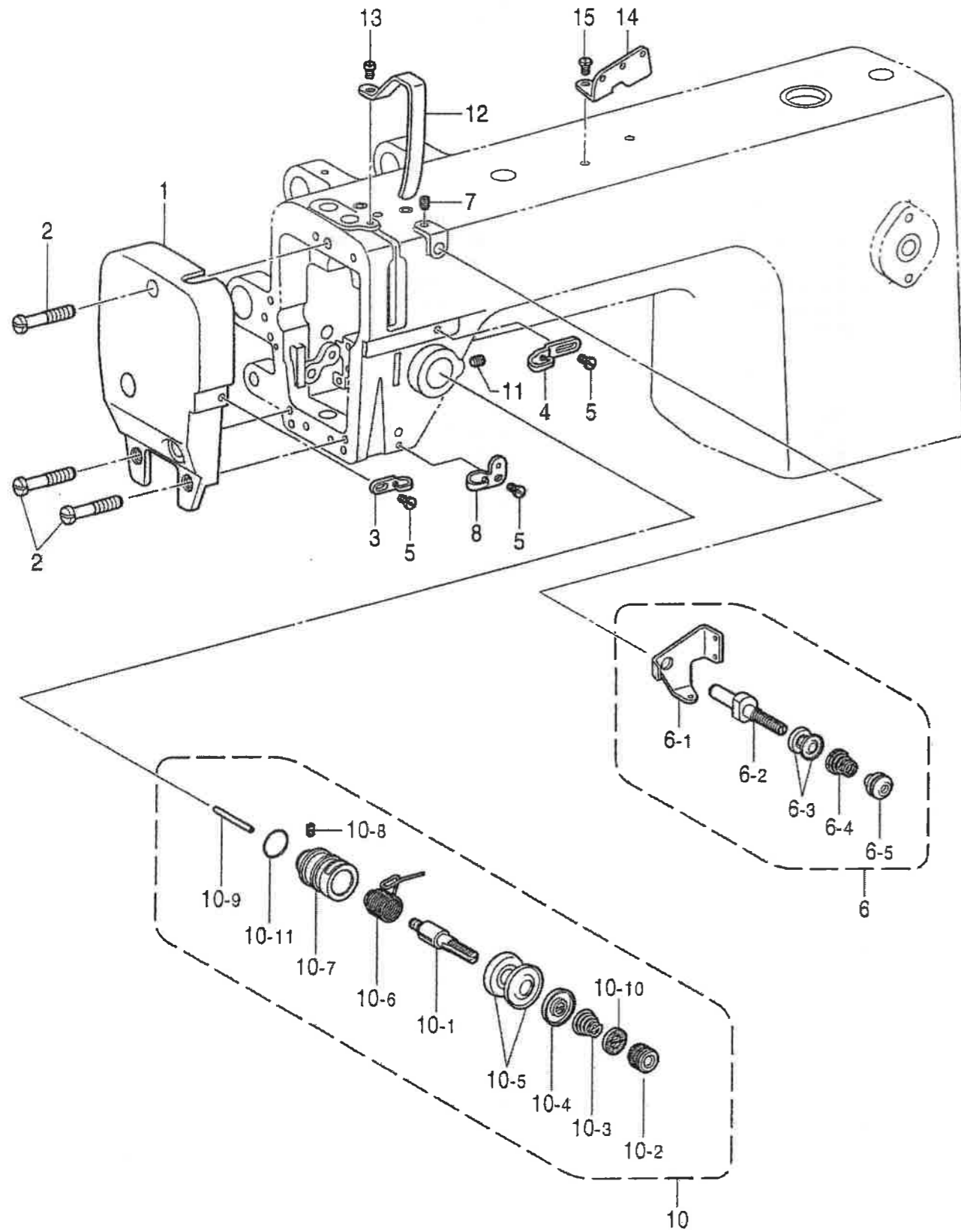

主体関係/Machine body

No	部品番号 PARTS No	員数 QTY	品名	DESCRIPTION
1	24500	1	油窓	OIL WINDOW
2	24501	1	Oリング	O-RING
3	24502	1	ゴム栓 (φ25.5)	RUBBER CAP (φ25.5)
4	24503	1	裏板	REAR COVER
5	24504	1	裏板パッキン	PACKING
6	24384	8	裏板締めねじ	SCREW, SM11/64x40 L=9
7	24385	8	裏板ワッシャー	WASHER, PLAIN
8	24371	2	ゴム栓 (φ19.0)	RUBBER CAP (φ19.0)
9	24374	1	ゴム栓 (φ5.7)	RUBBER CAP (φ5.7)
10	24490	1	油飛び防止カバー	COVER
11	24505	1	油飛び防止カバー締めねじ	SCREW, SM11/64x40 L=6
12	24370	2	ゴム栓 (φ8.8)	RUBBER CAP (φ8.8)
13	24372	2	ゴム栓 (φ11.8)	RUBBER CAP (φ11.8)
14	24506	1	ゴム栓 (φ19.0)	RUBBER CAP (φ19.0)
15	24373	1	ゴム栓 (φ27.0)	RUBBER CAP (φ27.0)
16	24003	1	定規板	RULER PLATE
17	24004	2	定規板止ねじ	SCREW, 11/64X40 L=5.5
18	24005	4	ベッド脚	BED LEG
19	24006	4	ばね座金	WASHER, SPRING

針棒・天秤関係/Needle bar and thread take-up mechanism

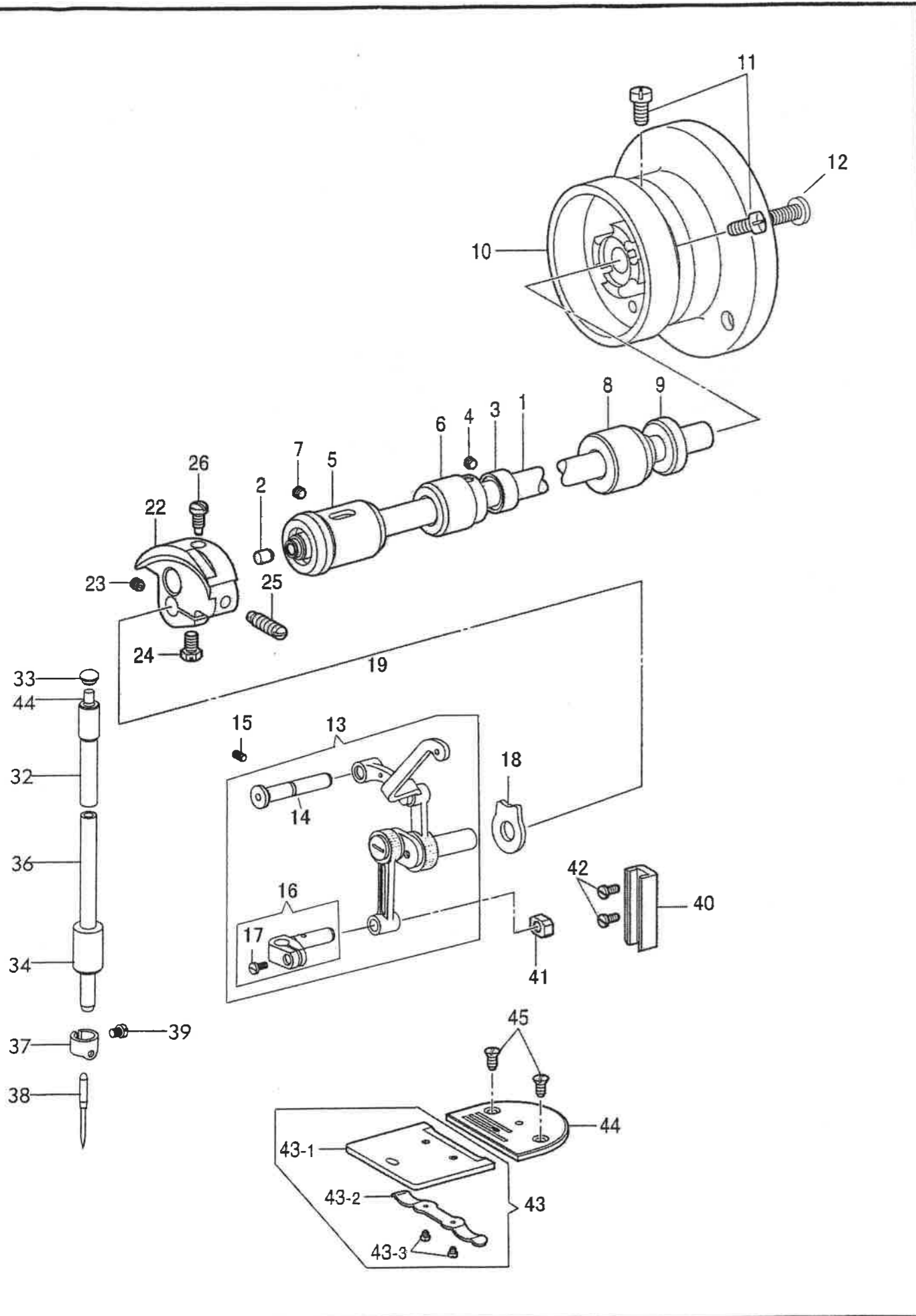

給油潤滑関係/Lubrication mechanism

No	部品番号 PARTS No	員数 QTY	品名	DESCRIPTION
1	24575	1	給油ポンプ	PUMP BODY
2	24335	3	締めねじ	SCREW, SM11/64x40 L=13
3	24576	1	給油ポンプ大ギヤ	OIL PUMP GEAR (LARGE)
4	24577	1	給油ポンプ小ギヤ	OIL PUMP GEAR (SMALL)
5	24578	1	給油ポンプ軸	OIL PUMP SHAFT
6	24355	1	給油ポンプ羽根蓋	OIL PUMP COVER
7	24357	1	給油ポンプフィルター (組)	FILTER SET
8	24356	1	油量調節板	THROTTLE PLATE
9	24354	1	ワッシャー	WASHER, PLAIN
10	24579	3	止めねじ	SCREW, M3x0.5 L=10
12	24390	1	油受け	OIL PAN
13	24391	1	油抜きねじ	SCREW, SM5/16x28 L=10
14	24392	1	油抜きリング	RING
15	24580	1	パッキン	PACKING
16	24395	1	膝上げ押し棒	KNEE LIFTRING BAR
17	24397	1	磁石	MAGNET
18	24359	1	オイルチューブ (下)	OIL TUBE, D
19	24360	1	油芯取り付け板	SETTING PLATE
20	24361	2	締めねじ	SCREW, SM9/64x40 L=11
21	24362	1	オイルチューブ (上)	OIL TUBE, U
22	24363	1	チューブ (組)	TUBE ASSY
23	24364	1	フェルト押え	FELT SUPPORT
25	24366	1	油芯	OIL WICK
26	24367	1	油芯 (組)	OIL WICK
27	24086	1	締めねじ	SCREW, SM11/64x40 L=6

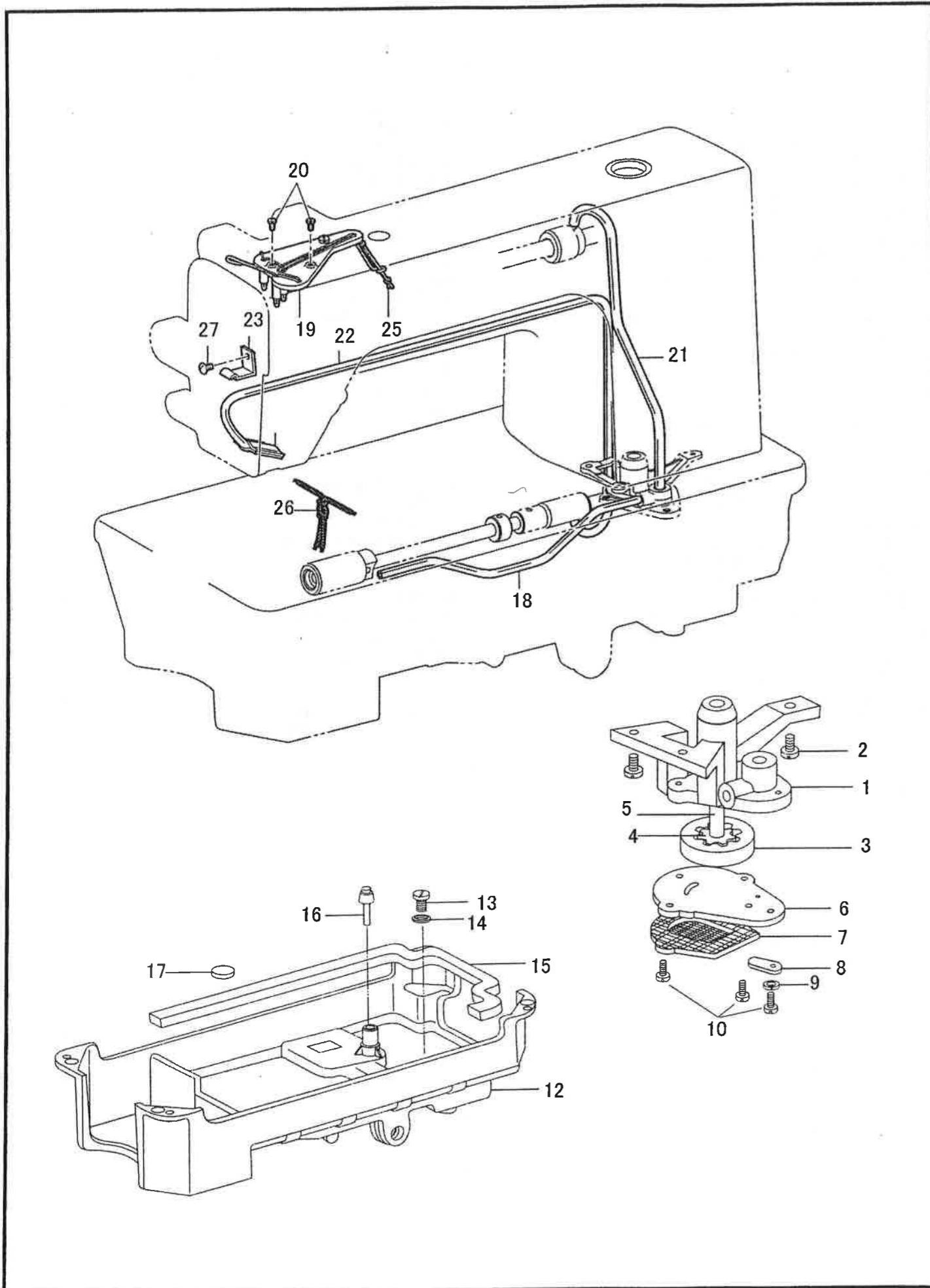

No	部品番号 PARTS No	員数 QTY	品名	DESCRIPTION
1	24507	1	上軸	UPPER SHAFT
2	24508	1	ゴム栓	RUBBER CAP
3	24012	1	セットカラー	SET SCREW COLLAR
4	24013	2	止ねじ	SET SCREW, SM1/4X40 L=4
5	24509	1	上軸メタルL	BUSH, L
6	24015	1	上軸メタルM	BUSH, M
7	24510	1	止ねじ	SET SCREW, SM15/64X28 L=13.5
8	24017	1	上軸メタルR	BUSH, R
9	24018	1	オイルシール	OIL SEAL
10	24019	1	プーリー	PULLEY
11	24020	2	止ねじ	SET SCREW, SM15/64X28 L=27
12	24511	1	止ねじ	SET SCREW, SM11/32X28 L=11
13	24512C	1	天秤(組)	THREAD TAKE-UP LEVER SET
14	24030	1	天秤支え軸	SUPPORT SHAFT
15	24513	1	止ねじ	SET SCREW, SM15/64X28 L=10
16	24052	1	針棒抱き(組)	NEEDLE BAR CLAMP
17	24514	1	締めねじ	SET SCREW, SM1/4X40 L=7
18	24489	1	座金	WASHER, PLAIN
22	24032	1	天秤クランク	THREAD TAKE-UP CRANK
23	24033	1	止ねじ	SET SCREW, SM1/4X40 L=7
24	24034	1	針棒クランク止ねじ	SCREW, 1/4X40 L=10.5
25	24035	1	天秤クランク止ねじ	SCREW, 9/32X28 L=18
26	24036	1	天秤クランク止ねじ	SCREW, 9/32X28 L=17
32	24040	1	針棒上メタル	BUSH, U
33	24042	1	キャップ	CAP
34	24043	1	針棒下メタル	BUSH, L
36	24045	1	針棒	NEEDLE BAR
37	24046	1	針棒糸案内	THREAD GUIDE
38	N0123	1	針 DPX17 #23	NEEDLE, DPX17 #23
39	24048	1	針止ねじ	SET SCREW, SM1/8X44 L=4.5
40	24049	1	針棒案内	GUIDE, NEEDLE BAR
41	24050	1	針棒案内角駒	SLIDE BLOCK
42	24051	2	針棒案内締めねじ	SCREW, SM11/64X4 L=8
43	24053	1	滑り板組	SLIDE PLATE ASSY
43-1	24054	1	滑り板	SLIDE PLATE
43-2	24055	1	滑り板バネ	SPRING, PLATE
43-3	24056	2	滑り板バネ締めねじ	SCREW, SM3/32X56 L=2.5
44	24516	1	針板	NEEDLE PLATE
45	24058	2	針板止血ねじ	SCREW, SM11/64X40 L=8

押え関係/Presser foot mechanism

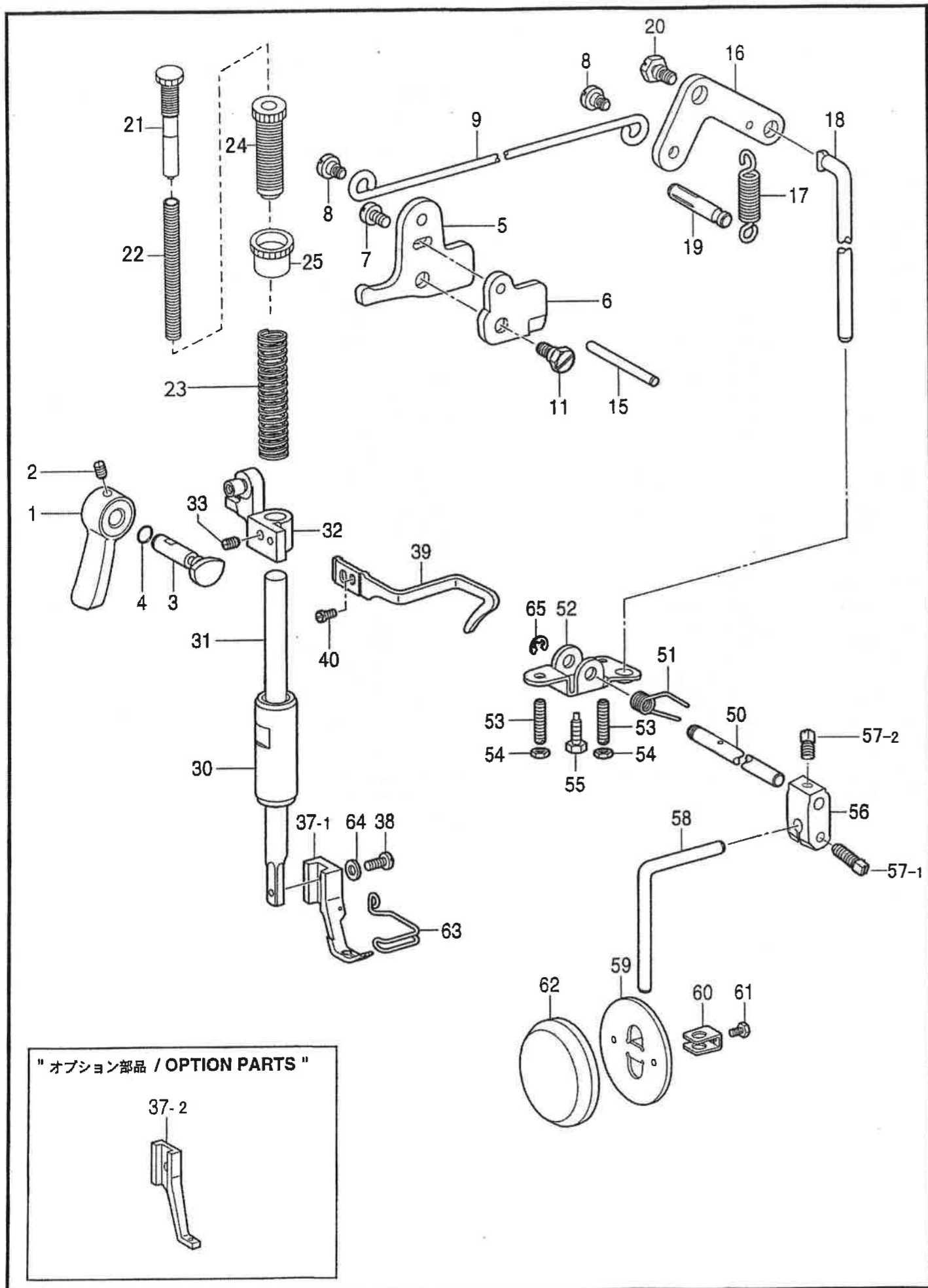

カマ関係/Rotary hook mechanism

No	部品番号 PARTS No	員数 QTY	品名	DESCRIPTION
1	24294	1	立軸	VERTICAL SHAFT
2	24567	1	上軸ギヤ	BEVEL GEAR
3	24033	2	止めねじ	SET SCREW, SM1/4x40 L=7
4	24568	1	立軸ギヤ (上)	BEVEL GEAR
5	24033	2	止めねじ	SET SCREW, SM1/4x40 L=7
10	24569	1	下軸ギヤ	BEVEL GEAR
11	24033	2	止めねじ	SET SCREW, SM1/4x40 L=7
12	24570	1	立軸ギヤ (下)	BEVEL GEAR
13	24033	2	止めねじ	SET SCREW, SM1/4x40 L=7
14	24571	1	立軸メタル (上)	BUSH, U
15	24301	1	立軸メタル (下)	BUSH, D
16	24805	2	止めねじ	SET SCREW, SM1/4x40 L=7
18	18850	1	ボビンケース (組)	BOBBIN CASE ASSY
19	18034	1	ボビン	BOBBIN
20	24540	1	カマ (組)	ROTARY HOOK ASSY
21	24540C	1	カマ、ボビンケース (組)	ROTARY HOOK, BOBBIN CASE ASSY
22	24314	1	下軸	LOWER SHAFT
23	24315	1	フィルター	FILTER
24	24316	1	フィルター栓ねじ	CAP SCREW, SM3/16
25	24317	1	下軸オイルシール	OIL SEAL
26	24318	1	下軸メタル (左)	BUSH, L
27	24319	1	油糧調節ねじ	ADJUSTING SCREW
28	24320	1	油糧調節ばね	SPRING
29	24321	1	セットカラー	SET SCREW COLLAR
30	24041	2	止めねじ	SET SCREW, SM15/64x28 L=5
31	24033	1	下軸メタル (右)	BUSH, R
32	24806	1	油パイプ	OIL PIPE
33	24332	1	プランジャー	PLUNGER
34	24333	1	プランジャーばね	SPRING, COMPRESSION
35	24334	1	プランジャー受け板	HOLDER PLATE
36	24572	1	ワッシャー	WASHER, SPRING
37	24573	1	締めねじ	SCREW, SM15/64x28 L=8
44	24336	1	内カマ押え	HOLDER
45	24079	1	止めねじ	SET SCREW, SM15/64x28 L=8
46	24574	2	メタル止めねじ	SET SCREW, SM15/64x28 L=13

カマ関係/Rotary hook mechanism

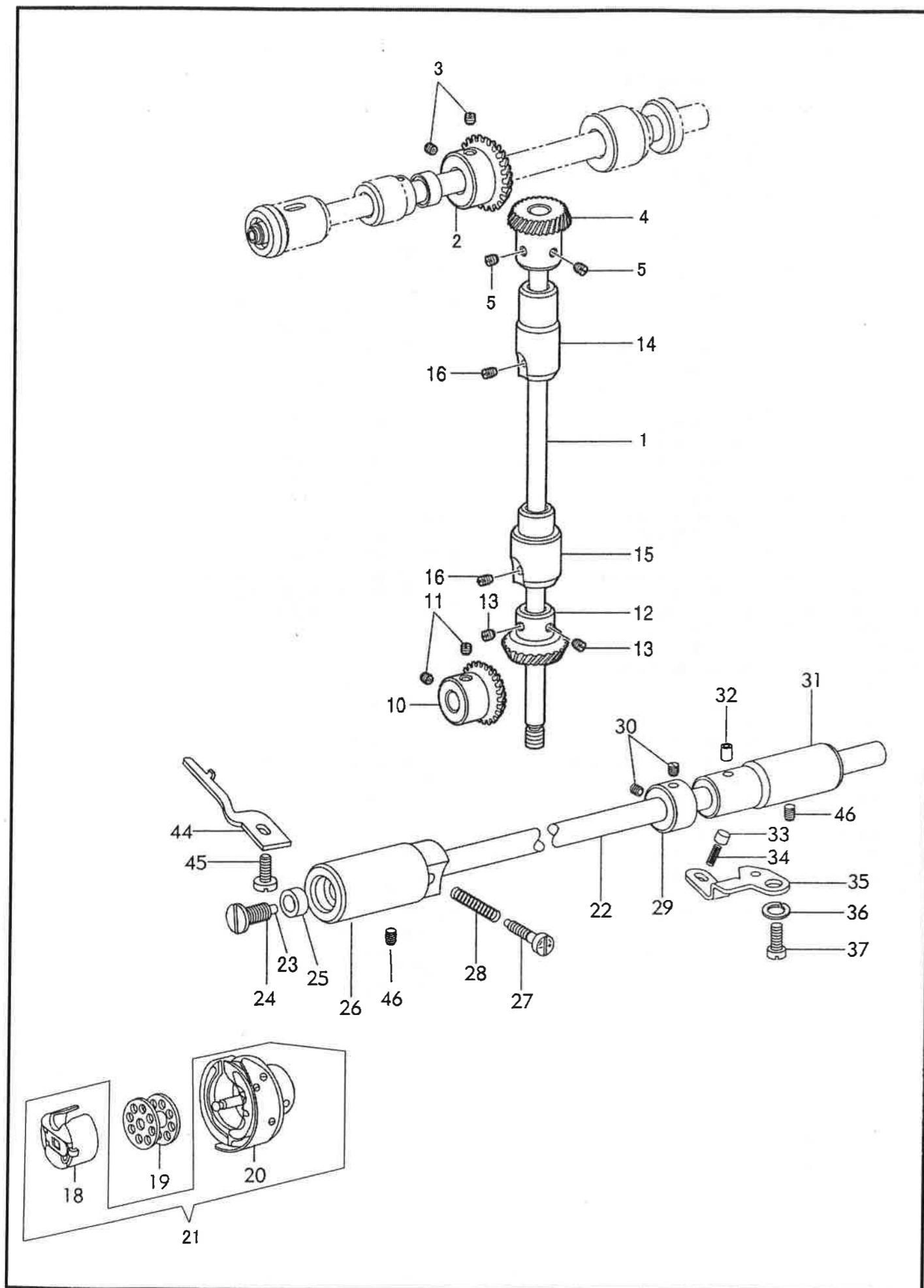

押え関係/Presser foot mechanism

No	部品番号 PARTS No	員数 QTY	品名	DESCRIPTION
1	24517	1	押え上げてこ	PRESSER BAR LIFTER
2	24518	1	止ねじ	SET SCREW, SM11/64X40 L=5
3	24062	1	押え上げクランク	LIFTER CRANK, P-BAR
4	24063	1	Oリング	O-RING
5	24064	1	押え上げレバー	LIFTER LEVER, P-BAR
6	24065	1	案内板	GUIDE PLATE
7	24066	1	押え上げレバー締めねじ	SCREW, SM11/64X40 L=6.5
8	24067	2	押え上げレバー段ねじ	SHOULDER SCREW, SM11/64
9	24519	1	膝上げ連結棒	CONNECTING ROD, K-LIFTER
11	24069	1	段ねじ	SHOULDER SCREW, SM15/64
15	24070	1	糸緩め軸	SHAFT
16	24071	1	膝上げレバー	LEVER, K-LIFTER
17	24072	1	膝上げレバーばね	SPRING, EXTENSION
18	24073	1	膝上げ棒	KNEE LIFTER BAR
19	24074	1	ばね掛け	SPRING HOOK
20	24075	1	膝上げレバー段ねじ	SHOULDER SCREW, SM15/64
21	24520	1	押え棒調節ねじ	REGULATING SCREW
22	24521	1	押えばね (小)	SPRING
23	24008	1	押えばね	SPRING, COMPRESSION
24	24522	1	押え棒筒ねじ	ADJUSTING SCREW, PRESSER
25	24523	1	筒ねじナット	ADJUSTING NUT, PRESSER
30	24076	1	押え棒メタル	BUSH, P-BAR
31	24524	1	押え棒	PRESSER BAR
32	24078	1	押え棒抱き	GUIDE BRACKET, P-BAR
33	24525	1	止ねじ	SET SCREW, SM15/64X28 L=8
37-1	24083	1	押え足	PRESSER FOOT
37-2	24526	1	押え足 (小物縫い)	PRESSER FOOT, SMALL
38	24084	1	押え足取付ねじ	SCREW, SM9/64X40 L=11
39	24085	1	押え棒抱き糸掛け	THREAD HOOK
40	24086	1	締めねじ	SCREW, SM11/64X40 L=6
50	24527	1	膝上げ横軸	LIFTER SHAFT
51	24091	1	膝上げばね	SPRING
52	24092	1	膝上げブラケット	BRACKET
53	24093	2	膝上げ調節ねじ	ADJUSTING SCREW, SM15/64X28 L=29
54	24094	2	膝上げ調節ねじナット	ADJUSTING NUT, SM15/64X28
55	24528	1	止ねじ	SET SCREW, SM15/64X28 L=15
56	24529	1	膝当て継手	BRACKET
57-1	24530	1	六角ボルトM6X1 L=12	BOLT, M6X1 L=12
57-2	24531	1	六角ボルトM6X1 L=20	BOLT, M6X1 L=20
58	24098	1	膝上げ縦軸	LIFTER BAR
59	24099	1	膝当て	KNEE LIFTER PLATE
60	24100	1	膝当てストッパー	STOPPER
61	24101	1	膝当てストッパーねじ	SCREW, SM15/64X28 L=8
62	24102	1	膝当てカバー	COVER, KNEE LIFTER PLATE
63	24532	1	フィンガーガード	FINGER GUARD
64	24104	1	平座金	WASHER, PLAIN
65	24396	1	E型止輪	RETAINING RING, E

上送り関係/Upper feed mechanism

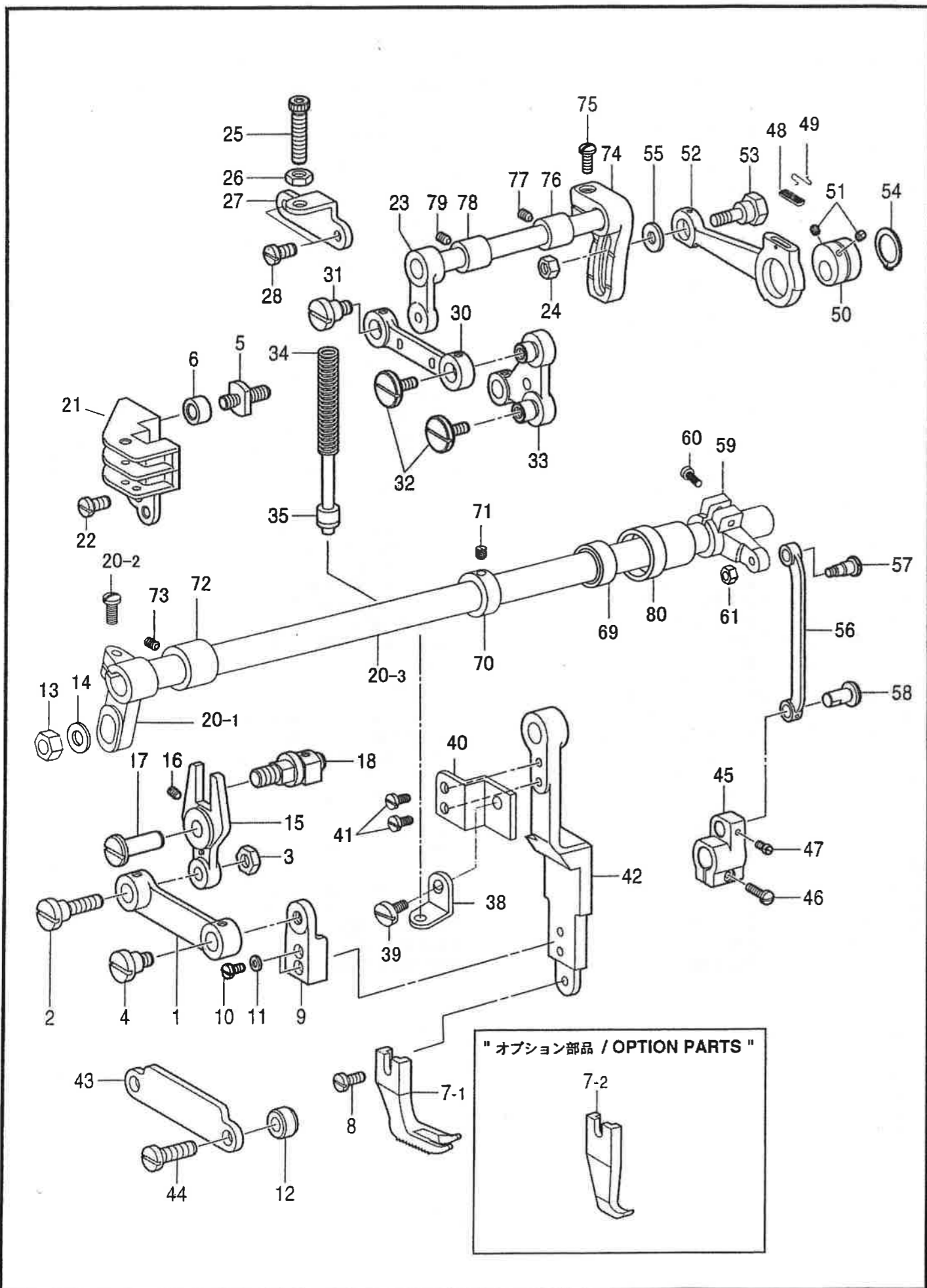

送り調節関係/Feed regulating mechanism

No	部品番号 PARTS No	員数 QTY	品名	DESCRIPTION
1	24543	1	切り換え器偏芯軸	ECCENTRIC STUD
2	24544	1	送り調節器	FEED REGULATOR
3	24136	1	止めねじ	SCREW, SM11/64x40 L=12
4	24163	1	調節器軸止めねじ	SCREW, SM15/64x28 L=8.5
5	24164	1	送り調節器軸メタル	BUSH
6	24165	1	送り調節器軸	STUD
7	24166	1	ゴムセン	RUBBER CAP
8	24545	1	止めねじ	SET SCREW
9	24176	1	レバー軸オリング	O RING
10	24170	1	レバー	LEVER
11	24546	1	レバーピン	PIN
12	24172	1	引きばね	SRING, EXTENSION
13	24173	1	レバー止めねじ	SET SCREW, SM15/64x28 L=14.5
14	24174	1	返し縫いレバー	REVERSE STITCHING LEVER
15	24175	1	返し縫いレバー軸	SHAFT, R-LEVER
16	24176	1	レバー軸オリング	O RING
17	24177	1	返し縫いレバー蓋ねじ	CAP SCREW, SM3/16x28 L=7
18	24547	2	返し縫いレバー止めねじ	SET SCREW
19	24179	1	送り調節ねじ	ADJUSTING SCREW
20	24180	1	調節ねじオリング	O RING
21	24181	1	送り目盛り板ダイヤル	STITCH LENGTH CONTROL DIAL
22	24182	1	送り目盛り板	STITCH LENGTH CONTROL PLATE
23	24183	1	目盛り板押え	SUPPORT PLATE
24	24184	1	目盛り板押え締めねじ	SCREW, SM3/16x28 L=12
25	24185	2	目盛り位置決めピン	POSITIONING PIN
26	24186	2	目盛り位置決めピンバネ	SPRONG, COMPRESSION
30	24190	2	水平偏芯カム止めねじ	SET SCREW, SM11/64x40 L=11
31	24191	1	水平偏芯カム	LEVEL FEED ECCENTRIC WHEEL
32	24192	1	水平送り連結	LEVER FEED CONNECTING ROD
33	24193	1	切り換え連結	CONNECTING ROD
34	24194	1	リンク軸	STUD
35	24195	2	水平送り腕リンク	LINK
36	24135	1	止めねじ	SET SCREW, SM11/64x40 L=5
37	24197	2	水平送りリンク	FEED LINK
38	24198	1	送りリンク軸R	SHAFT, R
39	24199	1	切り換え器止めねじ	SCREW, SM9/64x40 L=8.5
40	24200	1	送りリンク軸L止めねじ	SCREW, SM9/64x40 L=6.5
41	24201	1	送りリンク軸L	SHAFT, R
42	24202	1	切り換え器	FEED REGULATOR
43	24203	1	切り換え器軸L	SHAFT, L
44	24136	1	締めねじ	SCREW, SM11/64x40 L=12
45	24205	1	切り換え器軸R	SHAFT, R
46	24136	1	切り換え器軸R止めねじ	SCREW, SM11/64x40 L=12
47	24207	1	回り止め	STOPPER
48	24208	1	回り止めバネ	SPRING
49	24290	1	上下偏芯カム	ECCENTRIC WHEEL, UD
50	24291	2	上下偏芯カム止めねじ	SET SCREW, SM11/64x40 L=11
51	24292	1	連環押え	HOLDER
52	24293	1	上下送り連結	FEED CONNECTING ROD, UD

送り調節関係/Feed regulating mechanism

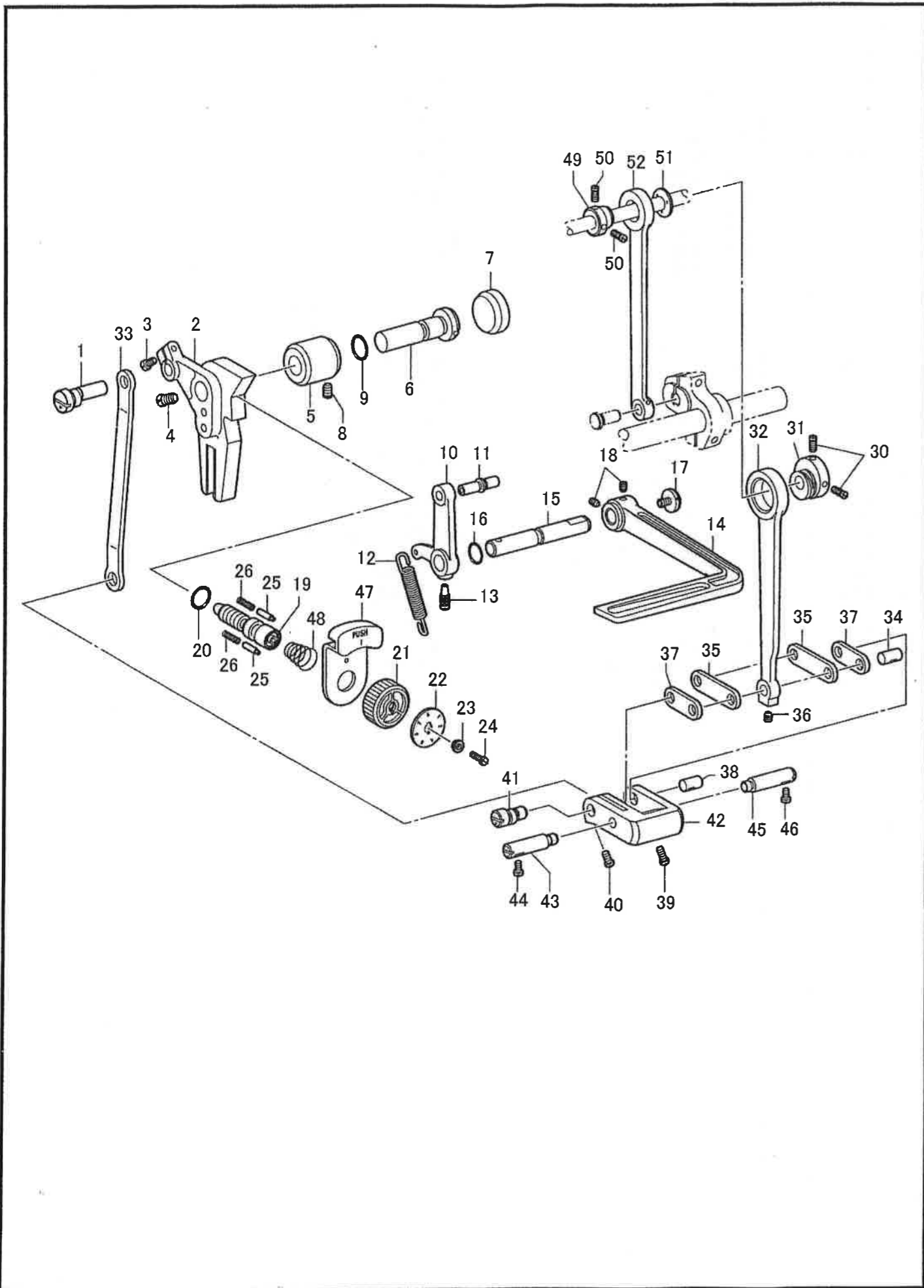

上送り関係/Upper feed mechanism

No	部品番号 PARTS No	員数 QTY	品名	DESCRIPTION
1	24210	1	リンクS	LINK, S
2	24211	1	リンクS段ねじ	SHOULDER SCREW
3	24212	1	リンクS段ねじナット	NUT, SM1/4
4	24213	1	リンク段ねじ	SHOULDER SCREW, SM1/4
5	24214	1	上送り上下コロ軸	ROLLER SHAFT
6	24215	1	上送り上下レバーコロ	ROLLER
7-1	24216	1	送り足	WALKING FOOT
7-2	24548	1	送り足(小物用)	WALKING FOOT, SMALL
8	24549	1	送り足取り付けねじ	SCREW, SM9/64x40
9	24218	1	送り足連結抱き	CLAMPER
10	24219	2	締めねじ	SCREW, SM9/64x40 L=7
11	24220	2	ワッシャー	WASHER, PLAIN
12	24221	2	カラー	COLLAR
13	24222	1	ナット	NUT, SM1/4
14	24550	1	ワッシャー	WASHER, PLAIN
15	24224	1	上水平送りレバー	LEVER
16	24225	1	送りレバー止めねじ	SET SCREW, SM3/16x32 L=7
17	24226	1	レバー軸	SHAFT
18	24227	1	コロ軸(組)	ROLLER SHAFT ASSY
20-1	24551	1	上水平送り腕	UPPER FEED ARM
20-2	24552	1	締めねじ	SCREW, 15/64X28 L=16
20-3	24553	1	上水平送り軸	UPPER FEED ROCKER SHAFT
21	24231	1	上送り上下レバー案内	LEVER GUIDE
22	24554	2	締めねじ	SCREW, SM11/64X40 L=8
23	24223	1	送り腕(軸付き)	FEEDING ARM SHAFT ASSY
24	24234	1	ナット	NUT, M6
25	24235	1	送り足押え棒バネ調節ねじ	ADJUSTING SCREW
26	24236	1	ナット	NUT, SM9/32
27	24237	1	送り足押え棒バネ受け台	BRACKET
28	24232	2	締めねじ	SCREW, SM11/64x40 L=8
30	24240	1	リンクL	LINK, L
31	24213	1	リンク段ねじ	SHOULDER SCREW, SM1/4
32	24242	2	送りレバー段ねじ	SHOULDER SCREW, SM3/16
33	24243	1	上送り上下レバー	FEED LEVER
34	24800	1	送り足押え棒バネ	SPRING, COMPRESSION
35	24801	1	送り足押え棒	PUSHER BAR
38	24802	1	送り足押え棒バネ受け板	HOLDER PLATE
39	24803	1	段ねじ	SHOULDER SCREW, SM1/4X40
40	24804	1	受け板止め板	SET PLATE
41	24219	2	締めねじ	SCREW, SM9/64x40 L=7
42	24251	1	送り足連結	CONNECTING ROD
43	24555	1	送り足連結案内	ROD GUIDE
44	24136	2	締めねじ	SCREW, SM11/64x40 L=12
45	24254	1	水平送り腕	FEED ROCKER ARM
46	24556	1	締めねじ	SCREW, 3/16X28 L=15.5
47	24135	1	止めねじ	SET SCREW, SM11/64x40 L=5
48	24557	1	フェルト	FELT
49	24558	1	フェルト押え	FELT CLAMP
50	24260	1	上送り上下カム	ECCENTRIC WHEEL
51	24559	2	上送り上下カム止めねじ	SET SCREW
52	24560	1	上送り上下連結	CONNECTING ROD
53	24263	1	上送り上下連結段ねじ	SHOULDER SCREW, M6
54	24264	1	C型止め輪	RETAINING RING, C
55	24265	1	上送り上下連結座金	WASHER, PLAIN
56	24266	1	上水平送り連結	CONNECTING ROD
57	24267	1	上水平送り連結段ねじ	SHOULDER SCREW, SM9/32
58	24268	1	上水平送り連結軸	STUD
59	24561	1	上水平送り連結腕	ARM
60	24562	1	上水平送り連結腕締めねじ	SCREW, 15/64X28 L=16
61	24236	1	ナット	NUT, SM9/32
69	24564	1	オイルシール	OIL SEAL
70	24012	1	セットカラー	SET SCREW COLLAR
71	24013	2	止めねじ	SET, SCREW, SM1/4x40 L=4
72	24272	1	上水平送り軸メタル(左)	BUSH, L
73	24041	1	止めねじ	SET, SCREW, SM15/64x28 L=5
74	24283	1	上下送り腕	FEED ARM
75	24270	1	上下送り腕締めねじ	SCREW, SM1/4x24 L=17
76	24284	1	メタル(右)	BUSH
77	24563	1	止めねじ	SET SCREW, SM15/64x28 L=6
78	24284	1	メタル(左)	BUSH
79	24563	1	止めねじ	SET SCREW, SM15/64x28 L=6
80	24565	1	上水平送り軸メタル(右)	BUSH, R

下送り関係/Lower feed mechanism

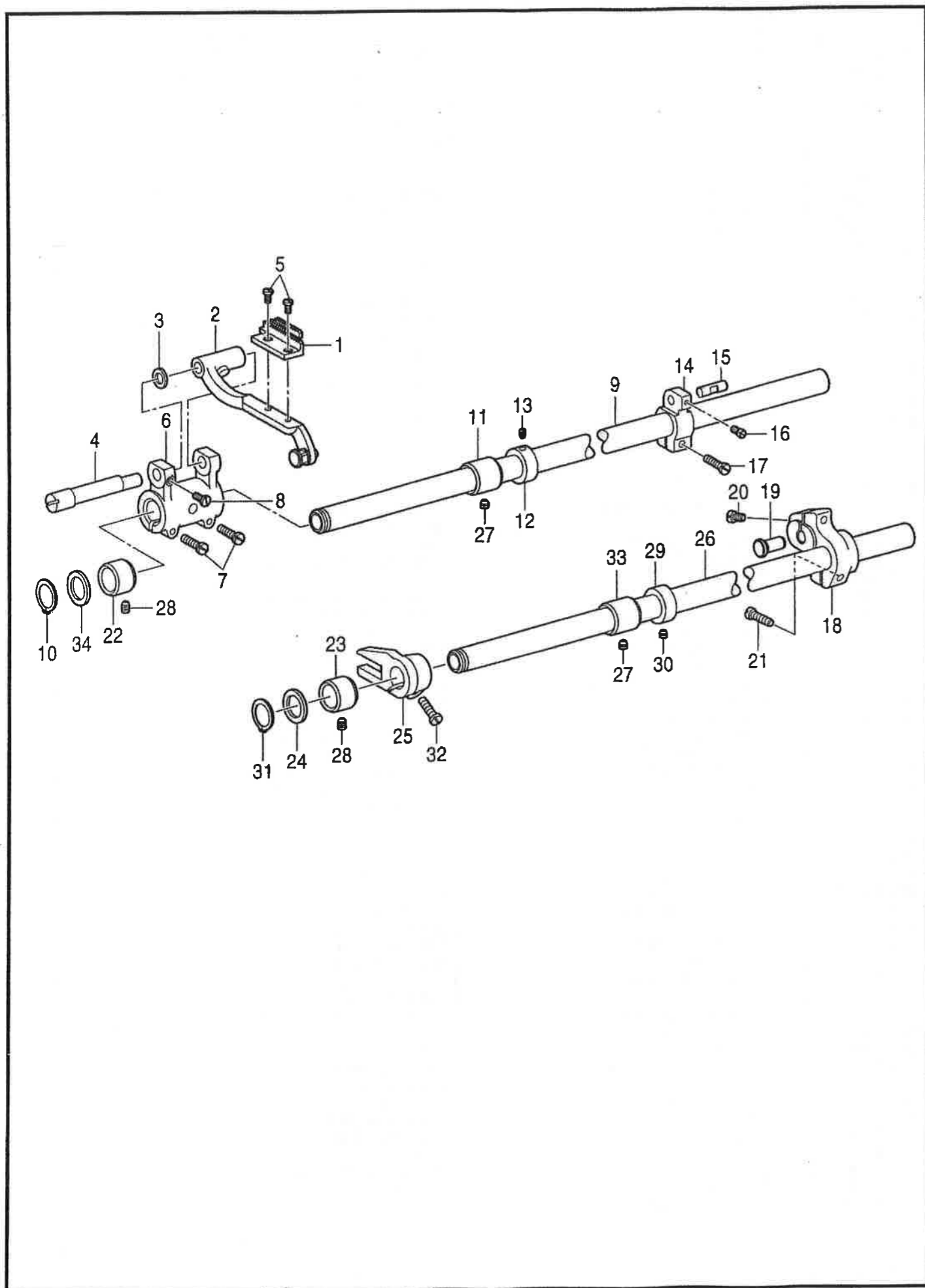

下送り関係/Lower feed mechanism

No	部品番号 PARTS No	員数 QTY	品名	DESCRIPTION
1	24533	1	送り歯	FEED DOG
2	24534	1	送り台	FEED BAR
3	24535	1	送り台ワッシャー	WASHER, PLAIN
4	24123	1	送り台軸	SHAFT
5	24536	2	送り歯締めねじ	SCREW, SM3/16x28 L=16
6	24125	1	水平送り台腕	FEED ROCKER ARM
7	24537	2	締めねじ	SCREW
8	24127	1	送り台軸止めねじ	SCREW, SM11/64x40 L=8
9	24128	1	水平送り軸	STUD
10	24129	1	C型止め輪	RETAINING RING, C
11	24130	1	水平送り軸メタルM	BUSH, M
12	24538	1	送り軸セットカラー	SET SCREW COLLAR
13	24013	2	止めねじ	SET SCREW, SM1/4x40 L=4
14	24133	1	水平送り腕	FEED ROCKER ARM
15	24134	1	水平送り腕軸	STUD
16	24135	1	止めねじ	SET SCREW, SM11/64x40 L=5
17	24136	1	締めねじ	SCREW, SM11/64x40 L=12
18	24539	1	上下送り軸腕	FEED LIFTING ARM, UD
19	24138	1	上下送り軸腕ピン	PIN
20	24126	1	締めねじ	SCREW, SM3/16x28 L=15
21	24541	1	送り軸腕締めねじ	SCREW
22	24141	1	送り軸メタルL	BUSH, L
23	24141	1	送り軸メタルL	BUSH, L
24	24142	1	上下軸ワッシャー	WASHER, PLAIN
25	24143	1	上下送り腕	FEED LIFTING ARM
26	24144	1	上下送り軸	SHAFT
27	24041	2	止めねじ	SET SCREW, SM15/64x28 L=5
28	24542	2	止めねじ	SET SCREW
29	24131	1	送り軸セットカラー	SET SCREW COLLAR
30	24013	2	止めねじ	SET SCREW, SM1/4x40 L=4
31	24129	1	C型止め輪	RETAINING RING, C
32	24150	1	上下送り軸腕締めねじ	SCREW, SM11/64X40 L=12
33	24130	1	水平送り軸メタルM	BUSH, M
34	24142	1	上下軸ワッシャー	WASHER, PLAIN