

ZJ600



# 暗 缝 机

TABLE BLIND STITCH MACHINE

零 件 手 册  
PARTS BOOK  
使 用 说 明  
PARTS BOOK

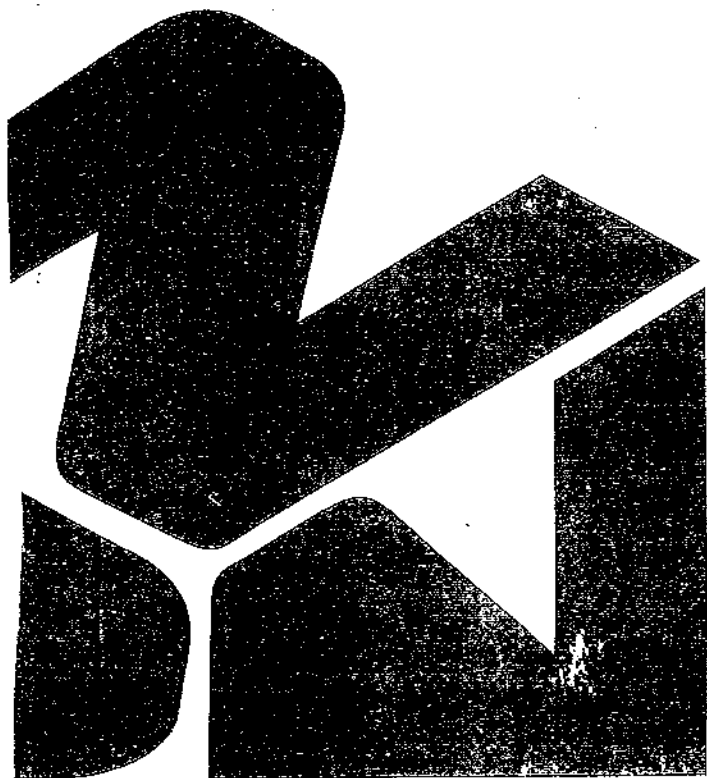

中国·中捷缝纫机股份有限公司  
ZOJE SEWING MACHINE CO., LTD

# 目 录

前 言	1
1、机器简介	2
2、主要技术规格	2
3、机器的安装和操作准备	3
1、机器的安装	3
(1)机头的取出	3
(2)机架的安装	4
(3)机头的安装	4
(4)托板组件的安装	5
2、操作前的准备	6
(1)擦拭机器	6
(2)机器检查	6
(3)机器的润滑	7
4、机器的使用	7
1、主轴的转向和转速	7
2、机针选择	7
3、缝线与机针配合	8
4、机针调换方法	8
5、穿线方法	9
6、缝料的压人和取出	9
7、跳针装置	10
8、送料牙高度调节装置	10
5、机器的调整	11
1、线迹长度的调节	11
2、暗缝深度的调节	12
3、压料板压力调节	12
4、机针与针板位置调节	13
(1)前后位置	13
(2)高低位置	13
(3)机针与左极限位置	14

(4)机针摆幅	15
5、钩线叉与机针位置的调节	15
(1)钩线叉的基本位置	15
(2)钩线叉的左右位置	16
(3)钩线叉的高低位置	17
(4)钩线叉的前后位置	18
6、抬料轮与压料板的位置调节	18
(1)左右位置	18
(2)前后位置	20
(3)抬料轮的拆装	20
7、压脚压力的调节	20
8、缝线张力的调节	21
6、供应方式	22
7、机头附件	22
8、机架附件	22
9、产品保修	23
10、零件样本	23
1、机壳和润滑组件	24
2、主轴组件	26
3、送料牙和针轴组件	28
4、钩线叉组件	30
5、针板组件	32
6、抬料轮和抬压脚组件	34
7、抬料轮传动及跳针组件	36
8、膝提压脚及止动组件	38
9、夹线器及锁线组件	40
10、托板组件	42

# TABLE OF CONTENTS

ForeWord.....	1
1. Brief Introduction to The MOdel.....	2
2. Main TeChnical Specifications.....	2
3. Mdashine Installation and Operation Preparation.....	3
1. Machine installation.....	3
(1)Unpacking machine head.....	4
(2)Fitting machine franme.....	4
(3)Fitting machine head.....	5
(4)Fitting Work plate componentS.....	6
2. Operation preparation.....	6
(1)Cleaning.....	6
(2)Inspection.....	6
(3)Lubrication.....	7
4. Opeation the Machine.....	7
1. Rotating direction and sewing speed of main shaft.....	7
2. Needle selection.....	8
3. Specifications.....	8
4. Needle replacemet.....	8
5. Threading.....	9
6. Faeding and pulling out of sewn materialS.....	9
7. Skip stitch device.....	10
8. Regulating feed dogs height.....	10
5. Adjustment of the Machine.....	11
1. Regulation of stitch length.....	11
2. Adjustmen of blindstitch sewing penetration.....	12
3. Regulation of the pressure of material retainer.....	12
4. Position regulation of needle and needle plate.....	13
(1)The front and the rear of position.....	13
(2)The positioning of location.....	14
(3)The left limit position of the needle.....	14

(4)The limit of needle throw.....	15
5. Regulating position of needle and thread hook.....	15
(1)Basic position of thread hook.....	15
(2)Positioning of location for pronged thread hook.....	16
(3)Adjustment of the position of the thread hook.....	17
(4)Positioning Of Location of thread hook .....	18
6. Regulating position of ridge forming disc and material retainer.....	18
(1)The left and right position.....	19
(2)Regulating of the front and the back posution.....	20
(3)Disassembling and fixing ridge forming disc.....	20
7. Regulating presser pressure .....	21
8. Regulating thread tension.....	21
6. Mode of Sale.....	22
7. Machine Head Accessories.....	22
8. Machine Frame Accessories.....	22
9. Warranty Period.....	23
10. Parts Book.....	23
1. Machine casing and lubrication components.....	24
2. Main shaft components.....	26
3. Feed dog and needle shan components.....	28
4. Thread hook components.....	30
5. Needleplale components.....	32
6. Ridge forming disc and lifting presser components.....	34
7. Disc oscillating and skip stitch components.....	36
8. Disc locking mechanism and knee lifting presser shaft parts.....	38
9. Thread tension and nipper parts components.....	40
10. Work plale components.....	42

# 前 言

型暗缝机是新推出并奉献给广大用户的一个新品种。本机广泛用于中西服、外衣、裙子的撬缝、扎卜等暗缝工序。但目前国内对该机种原理、使用、维修等各方面资料较少。为帮助用户能很好地掌握本机的使用和调整办法，特编写《使用说明》，供有关操作、维修和管理人员参考。

本机采用针杆挑线、摆动线钩勾线，由一根弧形针和一根线钩形成 103 型单线链式线迹，直形暗缝线缝。并设有压脚压力、缝线张力、线迹长度、暗缝深度、送料牙高度及暗缝间距比等调节机构。对各类不同厚度的缝料，只须调换相应零件（如机针、抬料轮等）和调节有关机构，就能满足不同制品的需要，故深受广大用户欢迎。

机器的使用寿命，不仅取决于制造质量，还与能否正确使用和维修密切相关，希望广大用户有关人员能认真阅读本说明书，熟悉本机结构和调整方法，以充分发挥机器效能，更好地为贵企业的经济效益服务。

## Foreword

blindstitch sewing machine, another product newly developed by conglomerate is now dedicated to customers. This Model is widely applied to blindstitching of either Chinese-style or Western-style clothes such as garments, skirts. Up to now, fewer literature covering maintenance, operation, and principles, has been available on domestic market.

To help customers have a good mastery of the essence of operation and adjustment of it, an "OPERATION MANUAL" is specially written for reference of service men, operators and administrative.

The model adopts needle bar thread take up and swing thread hook system so that an arc needle and a thread hook may form stitch type 103 chainstitch and straight blindstitch. It is also equipped with a regulating device for presser pressure, thread tension, stitch length, blindstitch penetration, height of feed dogs and blindstitch space etc. Only when appropriate parts such as needle, ridge forming disc are changed and particular mechanism regulated can the Model meet

the needs of sewing various sewn materials of different thickness. Thus it has been well received by numerous customers.

It's lifetime depends on not only manufacturing quality but also whether it is properly operated or repaired regularly.

Read instructions carefully before operating the machine.

## 1. 机器简介

### 1. Brief Introduction to The Model

ZJ600 型暗缝机是一种单弧针摆动刺料，摆动线钩勾线，形成103型单线链状线迹的工业缝纫机。它适用于缝制各类中等厚度织物的暗缝工序，如裤管口、上衣下摆的暗缝（俗称挑脚）及西装前胸暗缝（俗称扎卜）等的缝纫。

本机结构先进，设计合理，性能优良，运转平稳，噪音小，配合精密，寿命长，线迹优美，操作方便，是缝纫业必不可少的设备之一，欢迎顾客选用。

ZJ600 blindstitch sewing machine is ideal for blindstitching medium weight materials such as trouser leg seam, lower hem of garment, and the front of West-ern-style clothes etc.

The model has following features: Advanced construction, unique design, excellent performance, smoother running, precision fit, longer lifetime, aesthetic stitching, easier operation. It is one of indispensable pieces of sewing equipment.

Welcome to patronage.

## 1. 主要技术规格

### 1. Main Technical Specifications

(1) 最高缝纫速度	2500 针 / 分
(2) 额定缝纫速度	2000 针 / 分

(3)线迹长度	3—8 毫米
(4)暗缝间距比	1:1 2:1
(5)压脚降距	7 毫米
(6)采用机针	GL×1 型 NM75—100(LW×6T#3—#4)
(7)采用缝线	14.5—7.5tex 棉线或 14.8—7.4tex 涤棉线
(8)电机功率	270W
(9)机头外形	510×360×245(长×宽×高)
(10)机头净重	24.5 公斤

(1)Maximum sewing speed;	2500s. p. m
(2)Normal sewing speed;	2000s. p. m
(3)Stitch length;	3—8mm
(4)Blindstitch space ratios;	1:1 2:1
(5)Lift clearance of presser foot;	7mm
(6)Needle;	NM75—100 of Modle GL×1(LW×6T3#—4#)
(7)Thread;	14.5—7.5tex cotton thread or 14.8—7.4tex polyester cotton thread
(8)Electric motor power;	270W
(9)Overall dimension;	510×360×245(L×B×H)
(10)Net weight of machine head;	24.5Kg

### 3. 机器的安装和操作准备

### 3. Machine Installation and Operation Preparation

#### 1. 机器的安装

#### 1. Machine installation

##### (1)机头的取出

从货箱中取出机头时,不要损坏机头上凸出的零部件:如夹线器、过线环等。在取出所有部件和附件后,在没有仔细核对装箱单前,不要丢弃任何包装材料,以免丢失零件,影响生产。



### (1)Unpacking machine head

Unpacking machine head from its packing box. Be sure not to damage projecting parts of machine head such as thread tension assembly and thread guide etc. After unpacking all component parts and accessories, don't throw any packing material about without checking the packing list to avoid losing parts and impairing production.

#### (2)机架的安装

① 首先把后横档和踏板轴档与左右边架连接，再将踏板用踏板轴和踏板轴座与踏板轴档连接。

②将电动机与台板连接。

③将台板放到机架上面，中间用四只台板垫圈隔开后用四只台板木螺钉和垫圈将台板与机架固定。

④将上、下拉杆分别与电机及踏板杠杆连接，并套上拉杆接头，调整好踏板的左右和高低位置后，将踏板固定，将拉杆接头固定，使踏板定位。

#### (2)Fitting machine frame

① Frist connect rear stand side support and treadle shaft beam with side frame(left and right), and then link up treadle with treadle shaft beam by treadle shaft and treadle shaft base.

②Mount the motor onto the table.

③Put the table onto machine frame, partition the table at the centre with four table washers, and fix the table and machine frame with washers and wood screws.

④Connect upper and lower pull rod with motor and treadle lever, put on pull rod joint. After regulating position of treadle(left and right, high and low), fix the treadle and pull rod joint to locate the treadle.

#### (3)机头的安装

①将底盘防震垫“D”、机座底盘“C”、机座防震垫“B”、防震垫“E”、机头“A”依次放到台板上，对准四只孔后将四只小六角螺栓“F”从上到下插入孔中，依次套上防松垫“G”、平垫“H”后旋上六角螺母“I”，对角逐次旋紧四只螺母，将机头固定在台板上(图1)。

②将膝操纵杆“K”及套筒“L”与长轴前端连接，膝操纵杆横杆离台板“J”前端距离为1厘米时将套筒固定(图2)。

③装上三角带“N”，左右移动电机位置，使电机带轮与机头手轮对准后将电机固定在台板下，调节电机高低位置，使皮带松紧处于适宜状态。

④将电机开关固定在台板右前下方操作方便的位置上,接通电源。

### (3)、Fitting machine head

①Put pads "A", "B", "C", "D", "E" onto the table in order as shown in Fig. 1. Insert four hexagon head bolts with small head "F" into the holes. After putting on washers "G" and "H", put on hexagon nuts "I", tighten the four nuts diagonally, and fix the machine head on the table (Fig. 1).

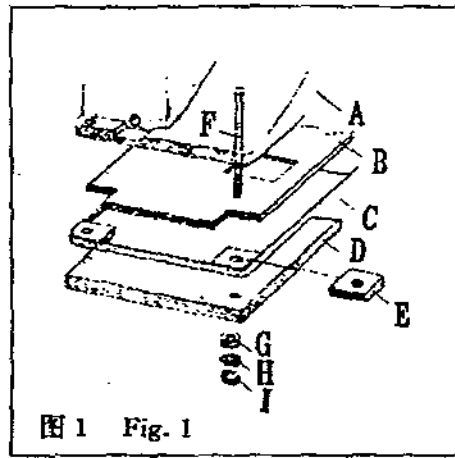

②Connect front end of long shaft with knee lifter "K" and sleeve "L". When the crossbar of knee lifter is 1 cm. distant from the front end of table "J", fix the sleeve (Fig. 2).

③Put on "V" belt "N", move the motor leftwards or rightwards so as to fix the motor under the sewing table after making the motor pulley in alignment with handwheel. Regulate the motor's height in order to make the belt in an appropriate state of tightness.

④First fix the motor switch at the bottom right place of the front end of sewing table for the convenience of operation, and then turn on the power.

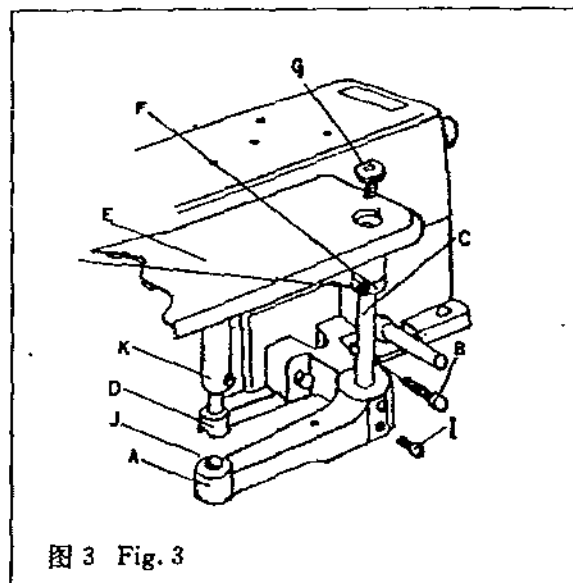
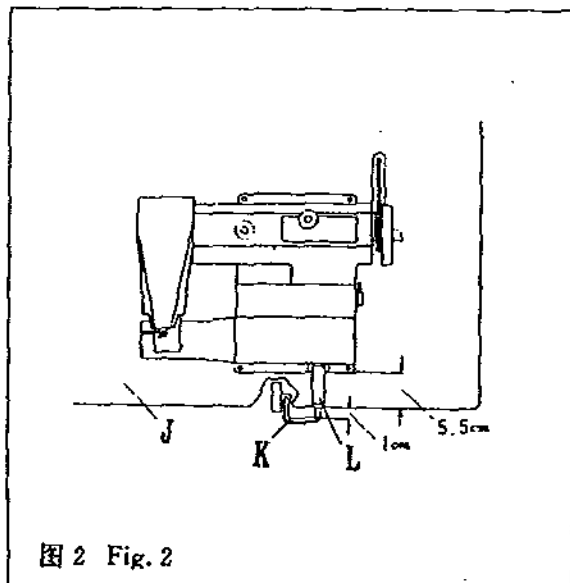

### (4)托板组件的安装(图 3)

①用支座螺钉"B"将支座"A"固定在机头上(顶销"J"和长、短弹簧片已预先组装好)。

②将轴肩螺钉"G"旋入托架轴"C"的螺孔中并紧后将托架轴从上向下插入支座孔中,再套上挡圈"F",旋紧挡圈螺钉"H",使托架轴定位,但转动应灵活。

- ③将定位销“D”插入定位套筒“K”的孔中，用螺钉按定位方向固定。
- ④将托架轴“C”插入支座右孔中，调节好托板“E”高度后旋紧螺钉“I”。
- ⑤开闭托板应灵活，能自锁。

(4) Fitting work plate components (Fig. 3)

① Fix bracket "A" on machine head with bracket screw "B" (Spring pin "J", short and long spring leaves are already assembled).

② First turn collar screw "G" up tight into the hole of work plate shaft "C", and then insert the work plate shaft into the hole of the bracket, finally put on retainer ring "F" and tighten retainer ring screw "H". Be sure to make the shaft rotate smoothly while securing the work plate shaft in place.

③ Insert positioning pin "D" into the hole of positioning sleeve "K" and turn it up tight with screw in direction of location.

④ Insert work plate shaft "C" into the right hole of the bracket, after regulating the height of the work plate "E", tighten screw "I".

⑤ Be flexible to open or close work plate; capable of auto-lock control of it.

2. 操作前的准备

2. Operation preparation

(1) 擦拭机器

新机头或久置不用的机头在使用前应将机头各部分的防锈油用汽油和清洁的软布擦拭干净。

(1) Cleaning

Before operating new machine head (or those which haven't been used for a long time), anti-rust grease on each part of machine head shall be cleaned out with gasoline and clean soft cloth.

(2) 机器检查

新机头在运输过程中可能受到强烈震动而使机件发生松动或变形，所以在清除油污后应对机器进行一次周密的检查。检查时用手转动手轮，观察机件有无碰撞、声响、重轧、松动等不正常现象。如有上述情况应排除后试车。

(2) Inspection

Some parts of new machine head may get loose or get out of shape due to vibration incurred in transit or rough handling, after cleaning, the machine shall be thoroughly inspected. To check the machine head by means of turning handwheel, the machine head shall be regulated and have a

test in case of abnormal phenomena such as running difficult of machine head, getting loose of some parts etc.

### (3) 机器润滑

机器在运转前应在各注油孔中加入数滴缝纫机油(图 4), 以保证机件相互摩擦的部位得到润滑, 并低速运转数分钟。新机头要求每班至少加油两次。为避免沾污缝料, 加油后让机器空载运转数分钟后措清各部分油渍再进行缝纫。

### (3) Lubrication

First inject several drops of oil at all points shown on the oiling chart Fig. 4 before operating machine so as to ensure the lubricating of the parts running against each other, and then operate the machine at a lower speed for several minutes. It is required to oil twice a day at least. After oiling the machine shall run idle for one or two minutes, and then clean the greasy dirt on each part of it, finally start sewing operation.

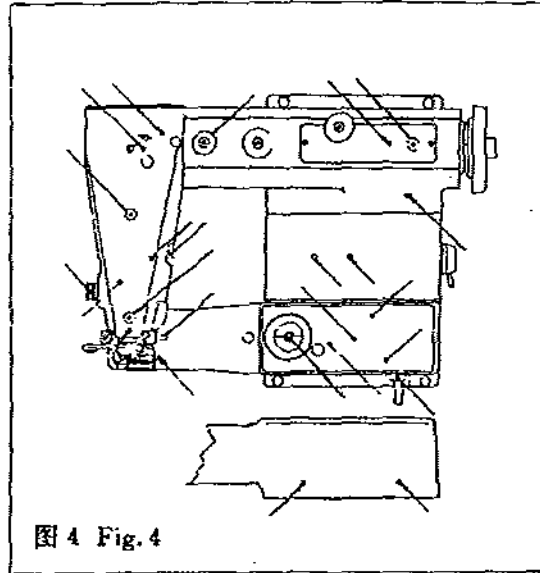

## 4. 机器的使用

## 4. Operating the Machine

### 1. 主轴的转向和缝速

本暗缝机手轮的转向, 从机头右端向左看, 应为顺时针转动。新机器在初期阶段使用时建议每分钟缝速在 1800 针以下为宜, 经过 1—2 个月的试用期, 并在操作人员熟练掌握本机的操作方法后, 可将缝速提高到额定缝速或较高些。

### 1. Rotating direction and sewing speed of main shaft

Rotating direction of handwheel shall be clockwise (observed from the right side to the left one), it is recommended that the sewing speed of a new machine shall be lower than 1,800s. p. m. In a period of one or two months of trial run, the sewing speed can be increased up to a max. normal one on condition that the operator has been skill in operating machine.

### 2. 机针选择

本暗缝机采用 GL×1 型 NM75—100 机针, 相当于日本 LW×6T 型 3 号~4 号机针。不同的

缝料应选用不同规格的机针。

## 2. Needle selection

The Model selects needle NM75-100 of model GL×1, on equivalent of Japan-made needle 3#-4# of model LW×6T. A certain kind of sewing material shall select a needle of an appropriate size.

## 3. 缝线与机针配合

从上面所述已知不同的缝针应选用不同规格的机针，缝纫时可根据缝料按下表选择适当的机针和缝线的规格。

### 机针、缝线与缝料配合

针号	线 号		缝 料
	棉 线	涤纶线	
75	7.5tex	7.4tex	130平布、涤棉、尼龙。
90	9.5tex		棉、毛及其他中等厚度织物。
100	14.5tex	14.8tex	灯心绒、厚呢及其他较厚的织物。

## 3. Specifications

Select proper needle and thread according to sewn materials.

Needle Size	Thread		Material
	Cotton Thread	Polyester Cotton Thread	
75	7.5tex	7.4tex	Light weight material
90	9.5tex		Medium weight material
100	14.5tex	14.8tex	Heavy weight material

## 4. 机针调换方法(图 5)

转动手轮使机针抵达左极限，将穿缝深度调节盘(旋钮)调至最小位置“1”，然后松开夹针螺钉“B”，取下旧机针，放入新机针“C”，校准定位面位置，并使针柄与定位销“E”接触，再旋紧夹针螺钉“B”。装好后慢慢转动手轮，并观察机针的运动，要求弧形针刃部分刚好对准针板左导针槽中间摆动，前后不碰槽为佳(具体机针的调整下面有专述)。最后再将旋钮调节到原来位置，并转动手轮观察机针与抬料轮相交时的接触情况以免机针针尖发毛，钝针、弯曲、发毛的机针一定要调换，以免影响缝纫性能。

## 4. Needle replacement(Fig. 5)

Turn handwheel until the needle reaches the left limit. Turn penetration dial(knob) toward position "1" (where minimum amount of penetration is indicated). Remove the worn-out needle by loosening needle clamp screw "B", and insert new needle "C". Calibrate the position of basic

surface, and make the shank come in contact with position pin "E".

Turn handwheel slowly and observe the movement of needle. The blade of arc needle shall be kept in line with the left needle guide groove and swing. Be sure not to touch the groove. (Procedure of adjusting the needle refer to the following relevant paragraph.) Regulate the knob to its original place, turn handwheel and observe the occurrence of the needle being crossing ridge forming disc to avoid making the needle point mildewed. Make sure that all bent, blunt or mildewed needles be replaced. Otherwise, it impaires the normal operational performance of the machine.

#### 5. 穿线方法(图 6)

转动手轮,使机针抵达左极限,然后按图示顺序穿线。

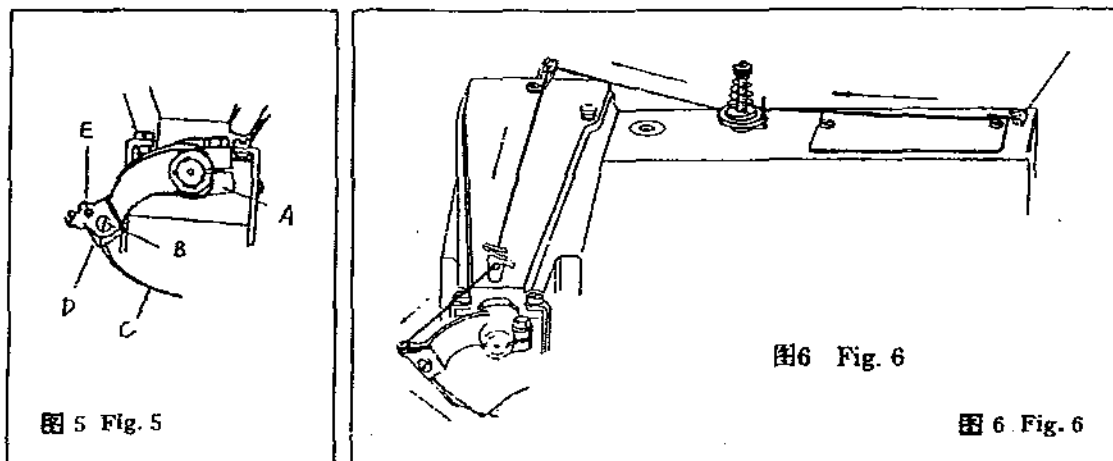

#### 5. Threading

Turn handwheel until the needle reaches the left limit, and thread in a sequence as shown in Fig.6.

#### 6. 缝料的压入与取出

缝切前先用膝部向右推动靠垫 "A"(图 7),使左右压脚 "B"和抬料轮 "C"降下,此时可将缝料送到针板 "E"下面,调好缝料位置后放松膝部施的力,压脚在弹簧的作用下将缝料压牢。

缝切结束后,先转动手轮使机针到达左极限后倒转手轮,使钩线叉上的缝线滑下,再用膝将压脚降下,然后将缝料轻轻拉出,剪断缝线。这样可避免断针、断线。

#### 6. Feeding and pulling out of sewn materials

Before operating, push pad "A" (Fig. 7) rightward by knee lifter to lower left & right presser foot "B" and ridge forming disc "C", at the same time, set material under needle plate "E". After regulating the position of material, release the knee pressure, the material has been pressed firm-

ly with presser foot by action of the spring. When sewing operation is finished, first turn the handwheel until the needle reaches the left limit, and then reverse it to make the thread slip off the thread hook, finally lower the presser foot by action of the knee lifter, pull out material softly and cut the thread. Thus breakage of needle and thread can be avoided.

### 7. 跳针装置

机头底座右下方, 装有间距调节手柄(图 8a)。当需要跳针缝时(暗缝间距比 2:1), 可将手柄转向前方(近操作者), 便能得到有规律的跳一针的线缝, 一般用于薄料(图 8b); 不需要跳针时(暗缝间距比 1:1), 可将手柄转向后方, 如图 8c 所示。

### 7. Skip stitch device

The handle for adjusting interval is fixed at the bottom right side of machine head base (Fig. 8a). When skip stitch is required, (blindstitch interval ratio: 2:1), turn the handle forward (towards the operator) so as to get a regular skip stitch. The said procedure is generally suitable for light weight material (Fig. 8b). When skip stitch is not required, (blindstitch interval ratio: 1:1) reverse the handle (Fig. 8c).



图 7 Fig. 7

图 8 Fig. 8

### 8. 送料牙高度调节装置(图 9)

在机头上臂座右侧中部, 安装有送料牙高度调节器。当顺时针转动送料牙高度调节旋钮“A”时, 送料牙就抬高, 用于轻薄料的缝纫, 逆时针转动“A”时, 送料牙就降低, 用于较厚料的缝纫。

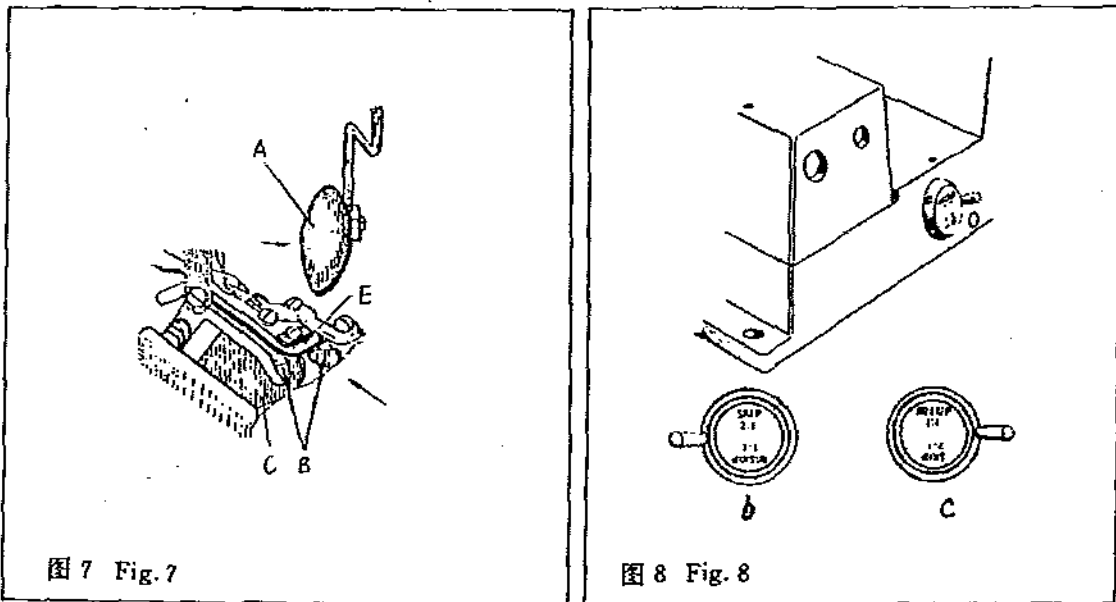
### 8. Regulating feed dogs height

Feed dogs height regulator is fixed in the middle at the right side of machine head upper arm

base. Turn the controller-knob "A" clockwise to raise the feed dog for the sewing of light weight material; turn the controller-knob "A" counter clockwise to lower the feed dog.



图9 Fig.9

## 5. 机器的调整

### 5. Adjustment of the Machine

#### 1. 线迹长度的调节(图 10)

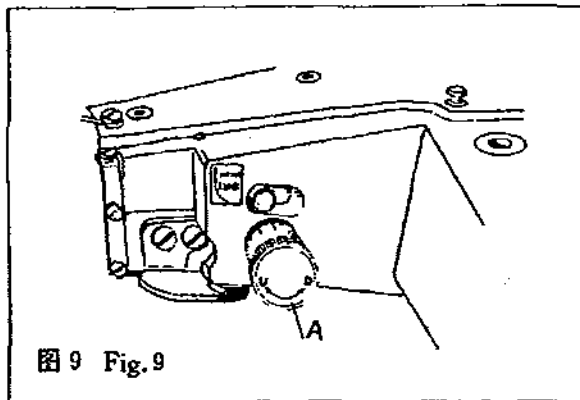
右手将手轮转动的同时,左手将机头上臂座后上方的线迹长度调节按钮压下。当线迹长度插销的下端嵌入线迹长度调节偏心套的凹槽中时会听到“答”的声音,同时左手也能感觉到插销落下一段距离。这时左手应继续压住按钮,而右手继续转动手轮,直至手轮左侧的数字与底座右边前斜面上的刻线对准,并且手感有轻轻卡轮时,说明安装在送料偏心滑套孔中的钢球在弹簧的作用下,已进入线迹长度调节偏心套的某一凹坑中,便认为调节到位。若要比该数字的线迹长度减小,则顺时针转动手轮;反之,则线迹长度增大。

带轮左侧的数字指示了线迹长度的变化趋势,并非直接代表其长度。本暗缝纫机线迹长度的调节范围为 3—8 毫米之间的接近整数的数值。用户可根据缝料和工艺要求,选择最佳的线迹长度。

#### 1. Regulation of stitch length (Fig. 10)

Depress controller-button located on the upper end of the rear of the machine head upper arm base by left hand while turning handwheel by right hand. Click can be heard when the lower end of the controller-plug is inserted into a recess of the eccentric sleeve. The falling of the plug can be felt by left hand. Keep depressing the botton and turning the handwheel by right hand until the indicated number on the left is in line with the graduation on right of the front oblique plane of the machine base. The steel ball in the hole of feed eccentric sliding sleeve has been inserted into a certain recess of the controller eccentric sleeve by action of the spring. In short, if a decrease in stitch length is required, turn the handwheel clockwise; if an increase in stitch length is required turn the handwheel counter clockwise.

Number on the left of the pulley indicates the changing of stitch length, the numbers doesn't mean stitch itself. The adjustment range of stitch length is from 3 to 8mm. Select the ideal stitch length according to sewn materials and processing requirement.



## 2. 暗缝深度的调节

在下臂座的中部安装有抬料轮高度调节器，它的中间是旋钮“A”，外边是指示圈“B”。抬料轮“C”的高度决定了暗缝的深度，而暗缝的深度必须根据缝料的厚度变化而变化。因此在缝纫前应先试缝几针，根据缝线暴露程度进行调节，使线缝达到最佳状态。

顺时针转动旋钮，抬料轮降低，减小暗缝深度；

逆时针转动旋钮，抬料轮升高，增大暗缝深度。

指示圈“B”上的刻度，指示了暗缝深度的趋势及旋钮转动的方向(图 11)。

## 2. Adjustment of blindstitch sewing penetration

Regulator for ridge forming disc height is fixed in the middle of the lower arm base, within which knob "A" is located and out of which indicating ring "B" is located. Blindstitch sewing penetration depends on the height of ridge forming disc "C", but penetration changes with the changing of thickness for sewn materials. Before operation, a trial sewing running of several stitches shall be made. Regulate penetration accordingly with the degree of exposure for stitching to make it in an ideal state. Turn the knob clockwise to lower ridge forming disc for a decrease of penetration; turn the knob counter clockwise to raise ridge forming disc for an increase of penetration.

Graduation on the indicating ring "B" indicates the changing of penetration and rotative direction of the knob (Fig. 11)

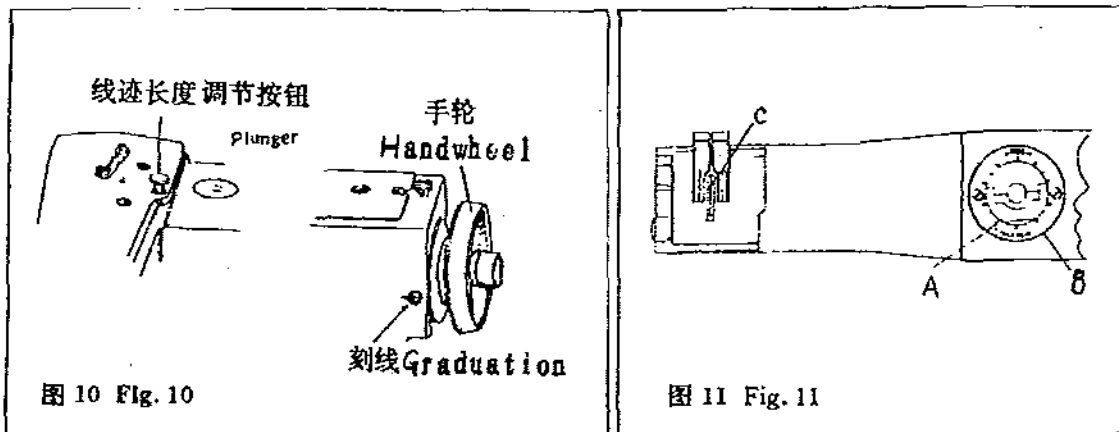

## 3. 压料板压力调节(图 12)

本暗缝机随机安装的针板属万能针板，即厚料、薄料兼用。缝纫时必须根据缝料厚度，对压料板“A”的压力进行调节。调节的方法是：顺时针转动调节螺钉“B”，压力增大，适用于厚料；逆时针方向转动调节螺钉“B”，压力减小，适用于缝薄料。

## 3. Regulation of the pressure of material retainer (Fig. 12).

The needle plate of this Model is a universal one, and suitable for both light weight and heavy weight sewn materials.

pressure of material retainer shall be regulated accordingly with the changing of thickness for sewn materials.

Regulating procedure is as follows:

A. Turn screw "B" clockwise to increase pressure for heavy weight materials.

B. Turn screw "B" counter clockwise to decrease pressure for light weight materials.

#### 4. 机针与针板位置调节

##### 4. Position regulation of needle and needle plate.

(1)前后位置 机针"B"前后位置应在针板左导针槽"C"中心通过(图 13a)。如果位置偏移应先旋松锁紧螺钉"A", 前后移动针夹"D"(图 13b)相对于针轴的位置, 使机针前后位置符合要求后将锁紧螺钉旋紧。

(1)The front and the rear of position.

The front and rear positions of needle "B" shall pass the centre of left needle guide groove "C" (Fig. 13a). If the needle is deviated from the centre, loosen lock screw "A", move needle clamp "D" (Fig. 13b) backward and forward in a frame of reference to the needle shaft. After the said positions complies with the requirements, tighten the lock screw.

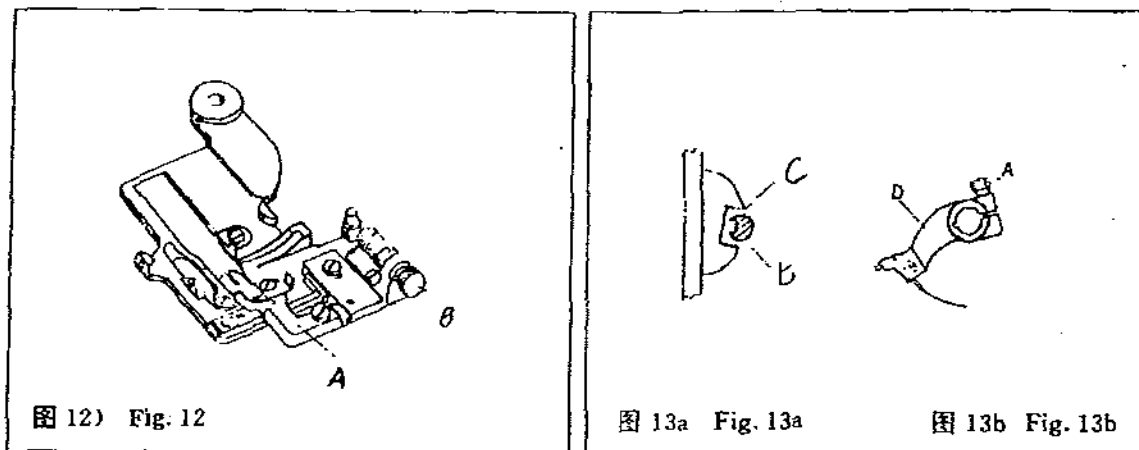

(2) 高低位置 机针与针板的高低位置有三处(图 14):

①机针与针板左导针槽"C"底面距离不大于 0.3 毫米;

②机针与机针护板"J"应轻微接触;

③机针与针板右导针槽底面 (K L 弧面)刚好接触。

如上述位置不正确就会引起断针、断线、跳针等故障。

调节方法：先旋松上臂座前两侧针板支架中部的两只支架紧固螺钉“H”，再转动针板上端的两只支架调节螺钉“I”，使针板发生上下位移，直至针板与机针的高低位置符合上述要求时，再旋紧针板支架紧固螺钉，使针板固定在正确的位置上(图 15)。

### (2) The positioning of location

There are three locations between the needle and the needle plate(Fig. 14):

① The space between the needle and the bottom surface of the left needle guide groove "C" shall be less than 0.3mm.

② Be sure to make needle come slightly into contact with needle guard "J".

③ Make the tip of the needle come right into the bottom surface (KL arc surface) of the right needle guide groove.

Incorrect positioning will result in breakage of needle and thread etc.

The following is the procedure of regulation:

Loosen two bracket set screws "H", and turn two bracket regulating screws "I" to make needle plate movable. When the relative location of the needle and needle plate is in accordance with the requirement, tighten bracket set screws of needle plate in place(Fig. 15).



图 14 Fig. 14



图 15 Fig. 15

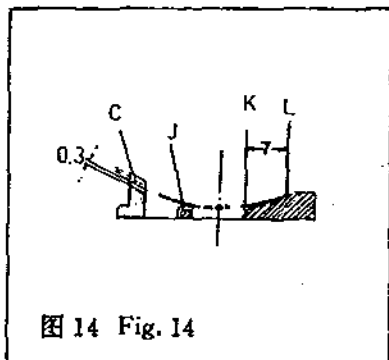

图 16 Fig. 16

(3) 机针左极限位置 机针的左右位置以左极限为基准，要求机针在左极限时，针尖与针板左导针槽的右侧面“F”平齐为机针的标准基准位置(图 16)。

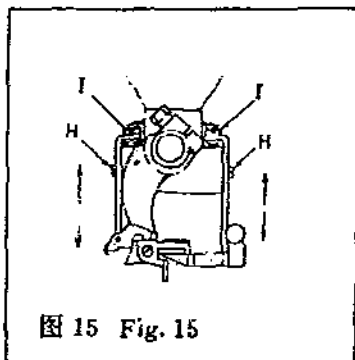
调整方法：转动手轮使机针到达左极限位置，如不符合上述要求，可将针夹锁紧螺钉“A”(图 13b)旋松，将针夹相对于针轴作转动，使针夹与针板左导针槽的右侧面平齐即可。

### (3) The left limit position of the needle

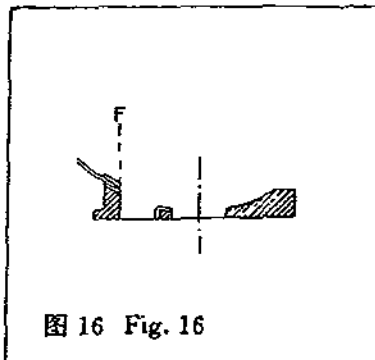
Left limit shall be taken as a frame of reference. When the needle is at the left limit, needle point shall be flush with the right side "F" of the left needle guide groove of needle plate(Fig. 16).

The regulating procedure is as follows:

Turn handwheel until needle reaches the left limit position. If needle doesn't accord with the said requirement, loosen needle carrier screw "A", turn the needle carrier on needle shaft until needle carrier shall be flush with the right side of the left needle guide groove of needle plate(Fig. 13b).

(4) 机针摆幅 机针的摆幅决定了机针右极限的位置。要求机针运动到右极限时，针尖到针板右侧面的距离为 2 毫米左右(图 17)，此时针尖刚好微露出右导针槽的极限点“E”(图 17)。如果上述位置不正确，必须调整机针摆幅。

调整方法：拆除上臂罩壳，将起子从上臂顶部起子孔“H”中伸入，松开锁紧螺钉“G”，再用起子转动偏心球轴销“F”，使针轴摆动角度发生变化，从而使机针摆幅达到要求(图 18)。

#### (4)The limit of needle throw

The right limit of needle depends on the limit of the needle throw. When the needle reaches the right limit, the needle point shall be in about 2mm distance from the right side of the needle plate (Fig. 17). At this moment, the needle point is right put out of the limit point "E" of the right needle guide groove(Fig. 17). If the positioning of location is incorrect, the limit of the needle throw shall be regulated.

The regulating procedure is as follows:

Remove the upper arm cover, loosen lock screw "G" with screwdriver through the hole "H" on the top of the upper arm.

Turn the eccentric ball shaft pin "F" with screwdriver to change the angle of the needle shaft throw. Thus make the limit of the needle throw comply with the requirements (Fig. 18).

### 5. 钩线叉与机针位置调节

#### 5. Regulating position of needle and thread hook

(1) 钩线叉的基本位置 钩线叉的基本位置由钩线叉曲柄“A”与主轴“B”的位置决定。安装时应将曲柄上的圆点“·”标记对准主轴上的“V”形槽中心时，将钩线叉曲柄固定(图 19)。

#### (1)Basic position of the thread hook

Basic position of thread hook is decided by positions of crank "A" of thread hook and main shaft "B". When the mark "." on the crank coincides with the center of "V" groove on the main shaft, fix the crank of thread hook in place (Fig. 19).



图 17 Fig. 17



图 18 Fig. 18

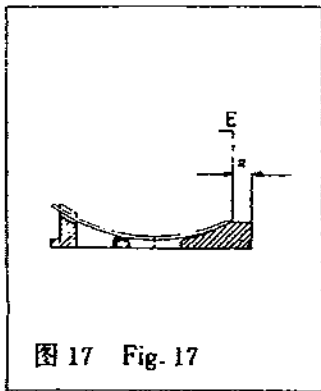

图 19 Fig. 19

## (2) 钩线叉的左右位置

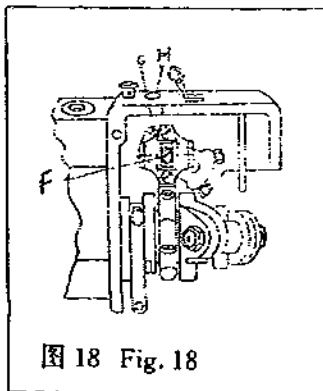
钩线叉的左右位置，当钩线叉的长叉尖与机针中心线相交时，长叉尖中心到机针穿线孔左边的距离为 2 毫米左右(图 20)。

调整方法：

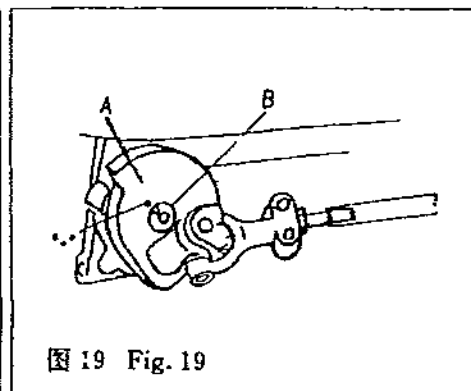
①旋松紧固螺栓“E”，左右移动偏心支承套“D”，达到上述要求时，旋紧紧固螺栓“E”(图 21)。

②转动手轮，检查钩线叉“F”运动到机针护板“K”的最近点“G”时是否相碰(图 22)，如果相碰必须将偏心支承套向左作微量调整。

③调整钩线叉曲柄上的圆点“·”标记与主轴“V”形槽的相对位置(图 19)对钩线叉的左右位置也有影响。所以调整钩线叉的左右位置，必须根据具体情况，在上述三步骤中仔细选择和反复进行调整，才能达到最佳状态。

## (2) Positioning of location for pronged thread hook

When the pronged thread hook intersects the central line of the needle, the centre of pronged thread hook is deviated from the left side of the needle eye in 2mm distance (Fig. 20).

Regulating procedure:

①Loosen set bolt "E", move the eccentric supporting sleeve "D" rightward and leftward, and tighten the set bolt "E" (Fig. 21).

②Turn handwheel to make the pronged thread hook "F" move towards the nearest point "G" of needle guard "K" (Fig. 22), if "F" comes into contact with "G", fine-adjustment of the eccentric supporting sleeve shall be made.

③ Adjustment of location of the mark "·" on the crank of thread hook in relation to "V" groove on the main shaft (Fig. 19) impairs the positioning of the location of the thread hook. Thus micro-adjustment of the position for thread hook shall be made accordingly. An ideal condition

of operation can be acquired only when careful selection and repeated adjustment have been made from the three said procedures.



图 20 Fig. 20



图 21 Fig. 21

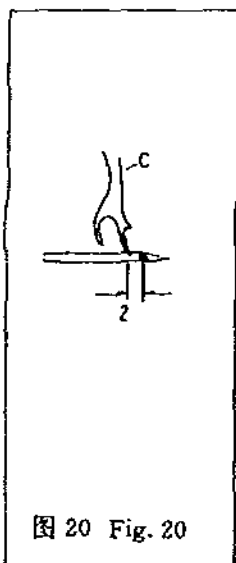

图 22 Fig. 22

(3) 钩线叉高低位置 钩线叉的高低位置以钩线叉叉尖与机针相交(图 20)时, 间隙很小但又不相撞为佳, 一般要求间隙不大于 0.05 毫米。

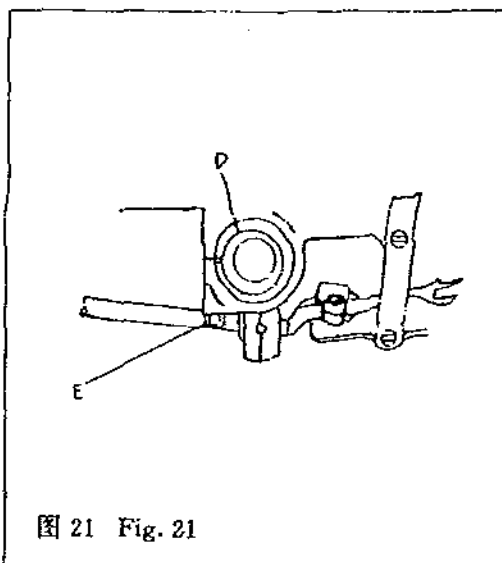
#### 调整方法

- ① 旋松紧固螺栓“E”(图 21), 周向转动偏心支承套“D”, 使钩线叉在右端时达到上述要求。
- ② 作上述调整后, 必须检查钩线叉在左端(图 23)时, 机针“H”的针尖应在钩线叉“C”的叉口中间或机针稍低于中间位置通过。如有相撞, 必须作相应调整, 达到左右兼顾。

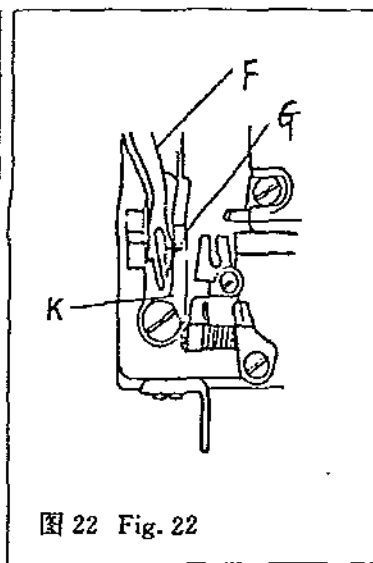
#### (3) Adjustment of the position of the thread hook

Make the prong of thread hook intersect the needle (Fig. 20) on condition that prong shall not come into contact with the needle. The interval between the prong and the needle shall be less than 0.05mm.

#### Regulating procedure:

- ① Loosen set screw “E” (Fig. 21) and turn the eccentric supporting sleeve “D” so that when the thread hook is at the right end may comply with the above-said requirements.
- ② When the thread hook locates at the left end (Fig. 23) after completing the said adjustment, the needle point “H” shall be in the middle of the prong of the thread hook “C”. The needle can also pass the thread hook at a location lower a bit than the middle. Micro-adjustment can be made if the needle point comes into contact with the thread hook.

#### (4) 钩线叉的前后位置

调整方法如下:

①运动关系调整 通过调整钩线叉曲柄上圆点“·”标记相对于主轴“V”形槽位置(图 19)。

②前后位置调整(图 24) 旋松钩线叉杆“I”后部调节螺母“F”和两只螺钉“H”,转动钩线叉杆一周,使钩线叉随之产生前后方向的位移来达到上述要求。

③经上述调整,前后位置尚未达到最佳状态,可旋松钩线叉紧固螺钉“K”,微量移动钩线叉的前后位置以达到最佳状态。微量调节时钩线叉杆前端面与钩线叉轴肩“C”之间间隙不大于 0.5 毫米。

#### (4) Positioning of location of thread hook

Regulating procedure:

① Adjustment of timing relation by regulating the position of the mark “·” on the crank of thread hook and “V” groove on the main shaft (Fig. 19).

② The front and back position of thread hook (Fig. 24)

Loosen regulating nut “F” and two screws “H” at the back of thread hook bar “I”, turn the thread hook bar one circle so that the thread hook brings about displacement forward and backward.

③ When the position adjusted does not comply with the requirement after completing regulation, loosen the thread hook set screw “K”, and move slightly the thread hook forward and backward. Interval between the front end of thread hook bar and shaft shoulder “C” shall be less than 0.5mm.

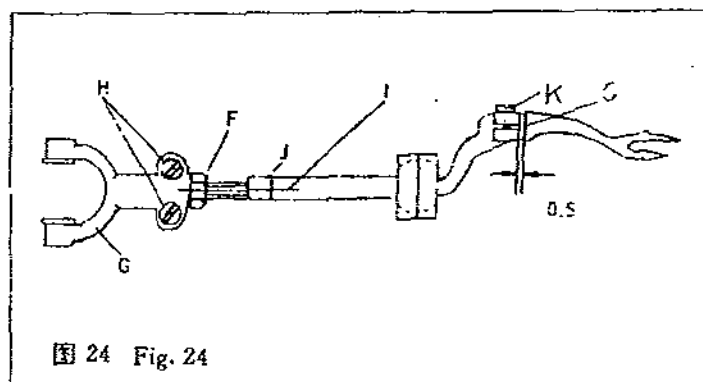
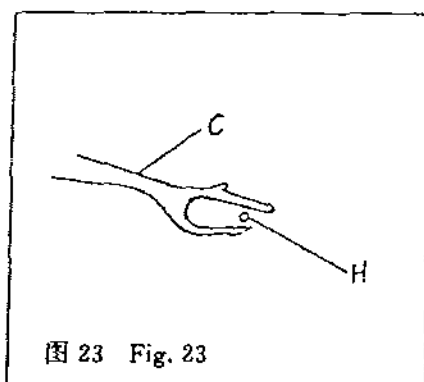

#### 6. 抬料轮与压料板位置调节

##### 6. Regulating position of the ridge forming disc and material retainer

(1)左右位置 抬料轮“C”的中心位置应与针板“A”上的压料板槽中心位置重合(图 25);压料板“D”的V形槽中心位置与抬料轮“C”中心位置重合(图 26)。

### 调整方法(图 27)

①首先旋松紧定螺钉“C”，转动顶尖螺钉“B”，使抬料轮调节杆“A”无轴向窜动，但又能灵活摆动，然后将紧定螺钉“C”旋紧。

②旋松卡圈“D”的锁紧螺钉“E”及曲柄“F”的锁紧螺钉“G”后将抬料轴左右移动，使抬料轮处于标准位置(图 25)时将锁紧螺钉“E”及“G”旋紧，并保持抬料轴无轴向窜动，但能灵活摆动，且与左右压脚板互不相碰。

③旋松压料板螺钉“A”，左右移动压料板“D”(图 12)使压料板 V 形槽中心与抬料轮中心重合(图 26)时，旋紧压料板螺钉。

(1) The left and right position.

The centre of the ridge forming disc "C" coincides with the centre of material retainer groove on needle plate "A" (Fig. 25); the centre of "V" groove of material retainer "D" coincides with the centre of ridge forming disc "C" (Fig. 26).

Regulating procedure:

① Loosen set screw "C" and turn pointed screw "B" to secure that the ridge forming disc regulating lever "A" swings nimbly and is kept from having axial play, and tighten set screw "C".

② After loosening lock screw "E" of collar "D" and lock screw "G" of crank "F", move the ridge forming disc leftward or rightward to set the ridge forming disc in a position required (Fig. 25), tighten lock screw "E" and "G". Make sure that the ridge forming disc shaft shall be kept from having axial play and swing nimbly. The ridge forming disc shaft shall not come into contact with either the left presser foot or the right one.

③ Loosen material retainer screw "A", move material retainer "D" (Fig. 12) leftward and rightward to make the centre of "V" groove on material retainer coincides with the centre of the ridge forming disc (Fig. 26). Tighten material retainer screw.

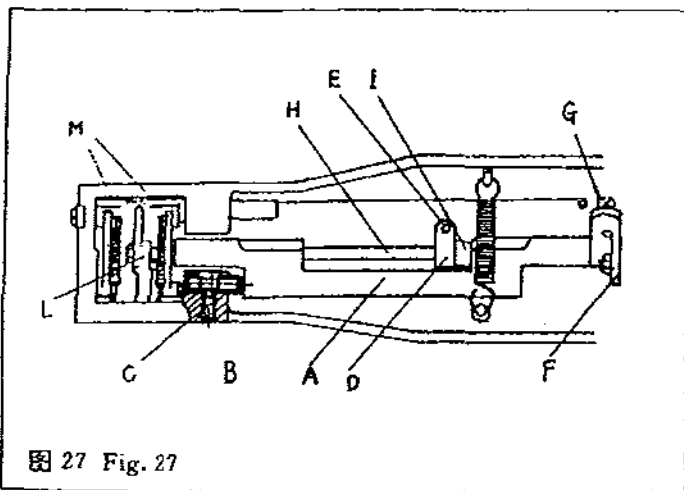
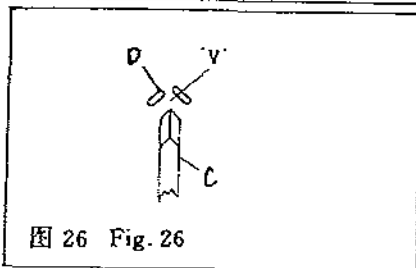
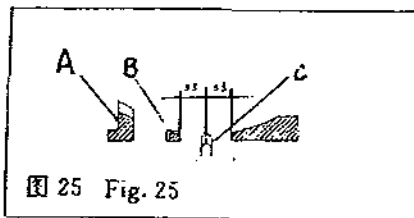



(2) 前后位置 抬料轮的前后位置以第一针为标准,当机针“P”针尖与抬料轮中心相交时,抬料轮“L”的后侧面到机针中心之间的距离为5毫米(图28),如果上述位置不正确,必须进行调整。

调整方法:转动手轮使机针“P”的针尖与抬料轮“L”中心相交(图28),然后旋松曲柄锁紧螺钉“G”(图27),转动抬料轴“H”(图27,29),使抬料轮后侧面离开机针中心5毫米(图28)时将曲柄锁紧螺钉“G”旋紧。最后检查一下抬料轴“H”应无轴向窜动,摆动应灵活。

### (2)Regulating of the front and the back position

Take the first stitch as a frame of reference to the positioning of ridge forming disc. When needle point "P" intersects the centre of ridge forming disc, the back side of ridge forming disc "L" is in 5mm distance from the centre of needle (Fig. 28). If incorrect location is positioned, adjustment shall be made.

Regulating procedure;

Turn handwheel until the needle point "P" intersects the centre of ridge forming disc "L" (Fig. 28). Loosen crank lock screw "G" (Fig. 27), turn the ridge forming disc shaft (Fig. 27,29) "H" until the back side of ridge forming disc is in 5mm distance from the centre of the needle (Fig. 28), tighten crank lock screw "G". Be sure to keep the ridge forming disc from having an axial play and make it swing nimbly.

(3) 抬料轮的拆装 如果拆装抬料轮“L”时,必须注意抬料轴“H”左端的螺纹与六角螺母“J”是左旋螺纹配合,拆装时必须注意转动方向,以免破坏螺纹。在安装抬料轮时,V形缺口必须对准弹性圆柱销“N”(图29)。

### (3) Disassembling and fixing ridge forming disc

If ridge forming disc "L" needs fixing or disassembling, careful attention shall be paid to the fact that the helical thread at the left end of the ridge forming disc shaft "H" cooperates with hexagon nut "J" by left-hand thread. When disassembling, special attention shall be paid to the rotating direction so as not to damage the helical thread. When fixing, the "V" notch shall be in line with the spring-type straight pin "N" (Fig. 29).

## 7. 压脚压力调节

压脚的压力应随缝料的厚度变化而变化,一般原则是缝料厚,压力大些;缝料薄,压力小些。

调整方法:

拆下罩壳螺钉“A”和下臂罩壳“B”,转动下臂左后部的两只小弹簧调节螺母“C”(图30)。从后向前看(图示位置)螺母,顺时针方向转动,压力增大;逆时针方向转动,压力减小。

## 7. Regulating presser pressure

Presser pressure shall be changed with the changing of sewn materials for different thickness. The pressure shall be increased when sewing heavy weight material; the pressure shall be decreased when sewing light weight material.

Regulating procedure:

Loosen screw "A" and remove the cover "B" from the lower arm (Fig. 30). Turn the nut "C" clockwise to increase the pressure; turn the nut "C" counter clockwise to decrease the pressure.

NOTE that the nuts shall be observed from the rear part.

## 8. 缝线张力调节

缝线张力的大小会影响缝纫质量。张力过大会引起缝料起皱断线等故障；张力太小，会出现跳针、浮线、不整齐等毛病。除有特殊要求的线缝外，一般正常的线缝应该是缝线与缝料结合密切，排列均匀、整齐，缝料不起皱。

本暗缝机的特点是：线迹长度大，张力应小；线迹长度小，张力应大。

调整方法：

顺时针转动夹线螺母"L"，缝线张力增大；逆时针转动夹线螺母"L"，张力减小(参阅图6中部夹线器部分)。

## 8. Regulating thread tension

Tension of thread impairs sewing quality. Tension higher than normal is to result in material puckering and thread breaking; tension lower than normal is to result in skipping stitch, floating, and uneven seams. The normal seam has features of even, pucker-free, and tightly-abutted stitching except for specified stitching.

Lower tension results in longer stitch; higher tension results in shorter stitch.

Regulating procedure:

Turn the tension nut "L" clockwise to increase thread tension; turn the tension nut counter clockwise to decrease thread tension. (Refer to thread tension assembly in Fig. 6)



图 28 Fig. 28

图 29 Fig. 29

图 30 Fig. 30

## 6. 供应方式

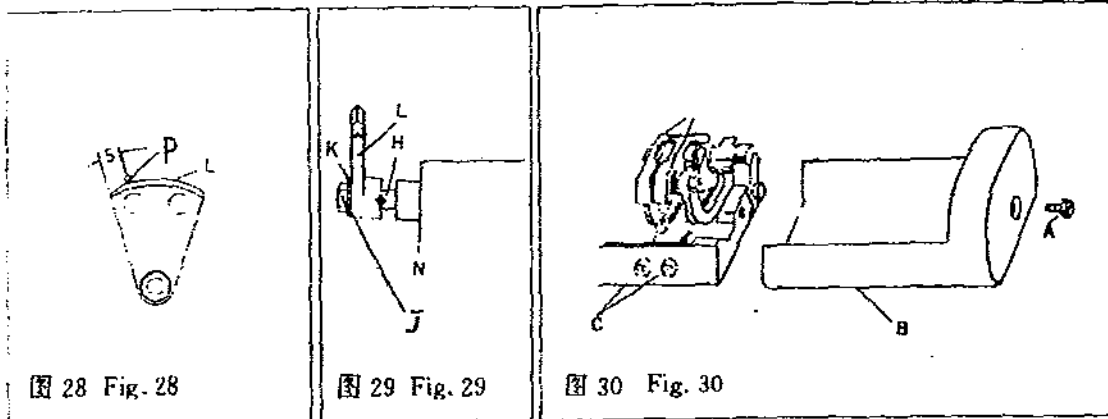
### 6. Mode of Sale

分 1 机头；2 全套(包括机头、机架及其附件)两种

(1) Transactions can be done on a basis of a sale of machine heads.

(2) Transactions can be done on a basis of a sale of units.

NOTE that a complete set of unit consists of head, frame and other accessories.

## 7. 机头附件

### 7. Machine Head Accessories

- ① 大 开 刀.....1 把,.....Large screwdriver..... 1 pc.
- ② 小 开 刀.....1 把,.....Small screwdriver..... 1 pc.
- ③ 油 壶.....1 只,.....Oil can ..... 1 pc.
- ④ 机 针.....1 包,.....Needle ..... 1 packet
- ⑤ 钩 线 叉.....1 只,.....Thread hook..... 1 pc.
- ⑥ 零 件 盒.....1 只,.....Parts box..... 1 pc.

## 8. 机架附件

### 8. Machine Frame Accessories

- ① 带 轮 离 合 器 电 动 机.....1 只,.....Clutch motor with pulley..... 1 pc.
- ② 线 架.....1 套,.....Spool rest..... 1 set

- ③ 三角带..... 1根; ..... "V" belt ..... 1 pc.  
④ 电动开关..... 1只。 ..... Motor switch ..... 1 pc.

## 9. 产品保修

### 9. Warranty Period

购买暗缝机，自购买之日起，一年内负责保修，在保修期内可送就近特约维修站进行免费修理，如系用户使用不当造成的则酌情收取零件费。

The warranty period begins when the blindstitch sewing machine is purchased. In no case will the warranty period extend beyond 12 months from the date of purchase.

During warranty period the product may be sent by the customer to the nearest service centre for repair free of charge.

Warranty service will not be performed on:

Products that malfunction because the customer has failed to observe good operating procedures.

## 10. 零件样本

### 10. Parts Book

### 1. 机壳和润滑组件

#### Machine casing and lubrication components

序号	件号	名称	数量
Ref. No.	Part No.	Description	Amt.
1	GK1-2	上臂罩壳..... Upper arm cover.....	1
2	GS1-2	上臂罩壳螺钉..... Upper arm cover screw.....	1
3	GS7-2	圆锥螺钉..... Taper cone screw .....	2
4	GK3-2	上臂后盖..... Upper arm rear cover .....	1
5	S40	盖板螺钉..... Cover plate screw.....	2
6	GK4-2	底座后盖板..... Rear cover plate of base frame .....	1
7	GS6-2	上臂后盖螺钉..... Upper arm rear cover screw .....	1
8	GK2-2	盖板..... Cover plate.....	1
	GR3-2	紫铜管..... Red copper tube.....	2
9	S40	盖板螺钉..... Cover plate screw.....	4
10	GR10-2	上臂橡胶塞..... Upper arm rubber plug.....	1
11	GQ1-2	底座..... Base frame .....	1
12	GK6-2	油孔盖..... Oil-hole cover .....	1
13	GS6-2	螺钉..... Screw.....	1
14	GK5-2	下臂罩壳..... Lower arm cover.....	1
15	GS2-2	下臂罩壳螺钉..... Lower arm cover screw.....	1
16	GR14-2	防震胶垫..... Shockproof rubber pad.....	4
17	GR15-2	底盘防震垫..... Shockproof pad of base pan .....	1
18	GR16-2	机壳底盘..... Machine casing base pan.....	1
19	GR17-2	机座防震垫..... Machine casing shockproof pad.....	1
20	GS103-2	小六角头螺栓..... Hexagon head bolt with small head.....	4
21	GR18-2	防松胶垫..... Rubber pad .....	4
22	GR201-2	平垫..... Washer .....	4
23	GL101-2	螺母..... Nut.....	4

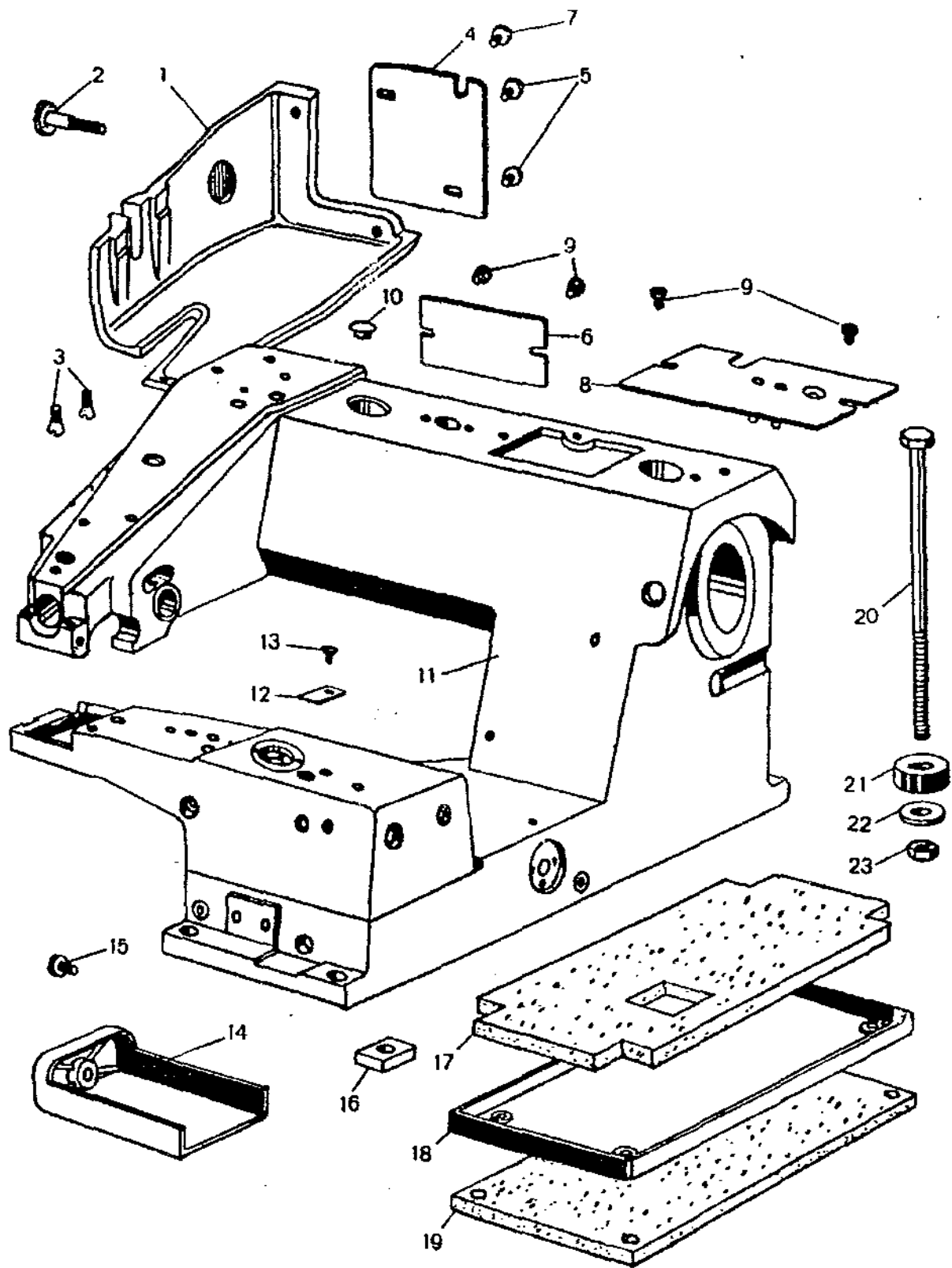

## 2 主轴组件

## Main shaft components

序号	件号	名称	数量
Ref. No.	Part. No.	Description	Amnt.
1	GO1-2	主轴左轴套..... Main shaft bushing (left).....	1
2	GS37	紧钉螺钉..... Set screw .....	2
3	GR4-2	主轴油毡..... Main shaft oil flet.....	2
4	GR1-2	主轴油塞..... Main shaft oil plug.....	1
5	GO3-2	平衡套..... Balance sleeve .....	1
6	GS8-2	锥端紧定螺钉..... Set screw with cone point.....	1
7	GS9-2	紧定螺钉..... Set screw.....	1
8	GO7-2	主轴右轴套..... Main shaft busing(right) .....	1
9	GZ2-2	主轴..... Main shaft .....	1
10	GO4-2	偏心轴套..... Eccentric bushing.....	1
11	GS50	紧定螺钉..... Set screw.....	1
12	GS50	紧定螺钉..... Set screw.....	1
13	GH1-2	连杆..... Connecting rod .....	1
14	GX3-2	连杆销..... Connecting rod pin .....	1
15	GO5-2	偏心衬套..... Eccentric sleeve .....	1
16	GX2-2	滑销..... Slide pin.....	1
17	GO6-2	主轴大齿轮衬套..... Main shaft large gear sleeve .....	1
	GC1-2	主轴大齿轮..... Main shaft large gear.....	1
	GX102-2	主轴大齿轮铆钉..... Main shaft large gear rivet.....	3
18	GC2-2	主轴小齿轮..... Main shaft pinion gear .....	1
19	GS43	紧定螺钉..... Set screw.....	2
20	GC4-2	惰性小齿轮..... Idler pinion gear.....	1
	GC3-2	惰性大齿轮..... Idler gear (large) .....	1
	GO10-2	惰性齿轮衬套..... Idler gear sleeve.....	1
	GZ3-2	惰性齿轮轴..... Idler gear shaft .....	1
	GX103-2	惰性齿轮铆钉..... Idler gear rivet .....	3
21	GO9-2	惰性齿轮偏心轴套... Idler gear eccentric bushing .....	1
22	GS37	紧定螺钉..... Set screw.....	1
23	GO8-2	挡圈..... Retainer ring.....	1
24	GS43	紧定螺钉..... Set screw.....	2
25	GPI-2	手轮..... Handwheel.....	1
26	GS37	紧定螺钉..... Set screw.....	2

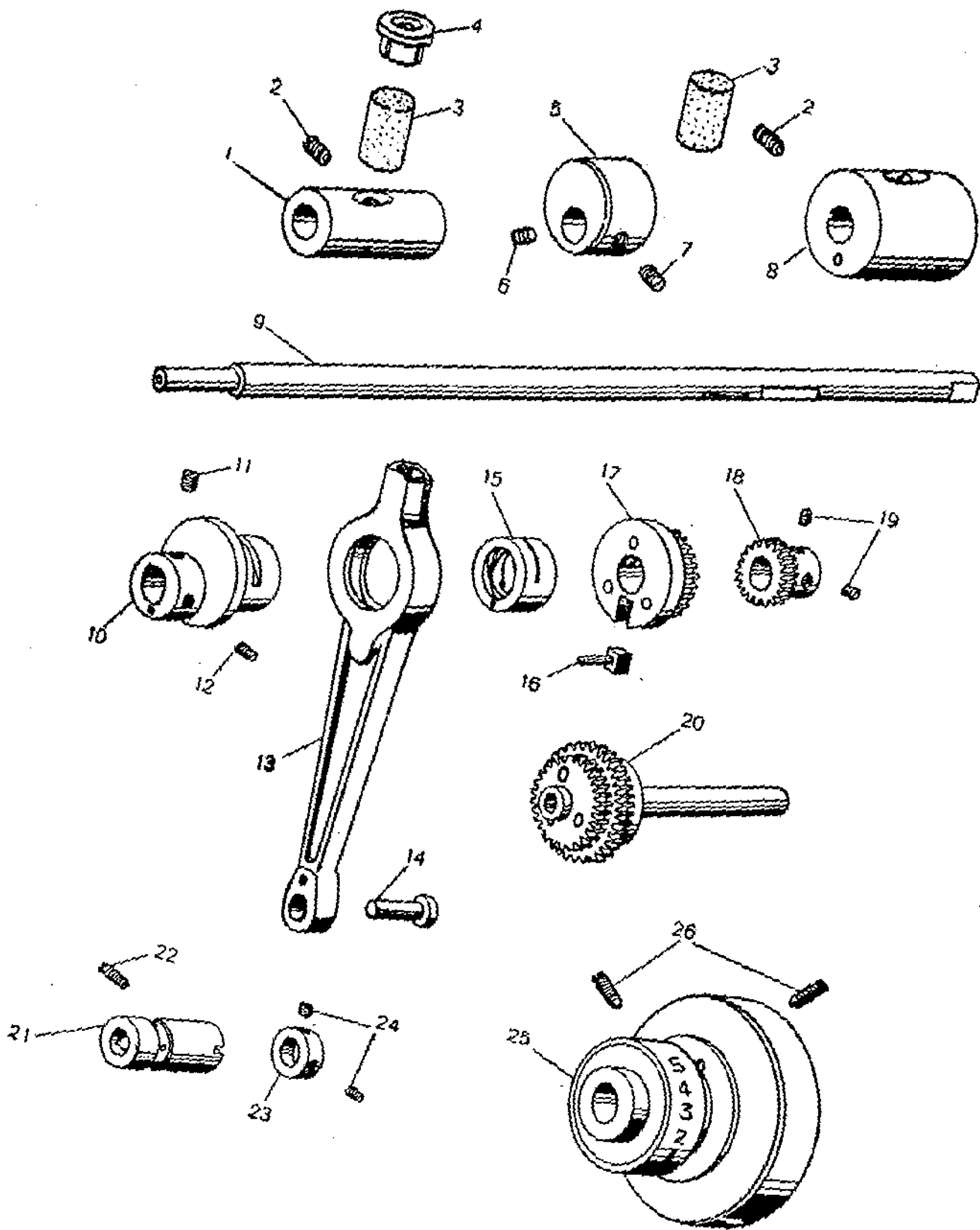



### 3. 送 牙和针轴组件

#### Feed dogs and needle shaft componets

序号 Ref. No.	件号 Part. No.	名 称 Description	数量 Amt.
1	GR164	针轴 油杯..... Needle shaft oil cup.....	2
2	GR11-2	针轴 油毡..... Needle shaft oil felt .....	1
3	GR11-2	针轴 油毡..... Needle shaft oil felt .....	1
4	GR30-2	针夹..... Needle carrier.....	1
5	CS15-2	锁紧螺钉..... Lock screw.....	1
6	GZ6-2	针轴..... Needle shaft.....	1
7	GO19-2	针轴挡圈..... Needle shaft retainer ring.....	1
8	GS43	紧定螺钉..... Set screw .....	2
9	GO18-2	针轴前轴套..... Needle shaft bushing(front) .....	1
10	GO17-2	针轴后轴套..... Needle shaft bushing(rear).....	1
11	GS8	轴套紧定螺钉..... Bushing set screw .....	2
12	GH4-2	针轴曲柄..... Needle shaft crank.....	1
13	GS61	曲柄固定螺钉..... Set screw on the crank.....	1
14	GS55	锁紧螺钉..... Lock screw.....	1
15	GR31-2	针夹板..... Needle carrier plate.....	1
	GR32-2	过线环..... Thread guide ring .....	1
16	GS16-2	夹针螺钉..... Needle carrier screw.....	1
17	GV1-2	机针..... Needle.....	1
18	GR29-2	偏心球轴销..... Eccentric ball shaft pin.....	1
	GR25-2	连杆上盖..... Upper cover of connecting rod .....	1
	GR26-2	连杆体..... Connecting rod.....	1
	GR27-2	连杆下盖..... Lower cover of connecting rod .....	1
	GO15-2	球偏心套..... Ball eccentric sleeve .....	1
	GO14-2	送料偏心滑套..... Feed eccentric sliding sleeve .....	1
	GO13-2	线迹长度调节偏心套..... Stitch length regulating eccentric sleeve.....	1
19	GS14-2	螺钉..... Screw.....	2
20	GS55	螺钉..... Screw.....	2
21	GS13-2	内六角锥端紧定螺钉..... Hexagon socket screw with cone point .....	1
22	GS12-2	限位螺钉..... Limit screw.....	2
23	GR21-2	钢球..... Steel ball .....	1
24	GW3-2	弹簧..... Spring .....	1
25	GR28-2	偏心球轴销护..... Protecting cover .....	1
26	GS44	螺钉..... Screw.....	2
27	GO16-2	线迹长度调节插套..... Regulating latch sleeve .....	1
	GW5-2	插销弹簧..... Latch spring .....	1
	GX4-2	线迹长度调节插销..... Stitch length regulating latch .....	1
	GR24-2	线迹长度调节按钮..... Stitch length regulating press-botton .....	1
28	GS45	插套紧定螺钉..... Latch sleeve set screw .....	1
29	GH2-2	送料杆..... Feed lever .....	1
30	GM1-2	送料牙..... Feed dog .....	1
31	GR202-2	内齿弹性垫圈..... Spring washer with internal teeth.....	2
32	GS10-2	螺钉..... Screw.....	2
33	GH3-2	送料摆杆..... Feed swing link .....	1
	GZ5-2	摆杆销轴..... Swing link pin rod .....	1
34	GS037	锁紧螺钉..... Lock screw .....	1
35	GS11-2	内六角凹端紧定螺钉..... Hexagon socked set screw with cup point.....	1
36	GZ4-2	销轴..... Pin rod.....	1
37	GO12-2	偏心衬套..... Eccentric sleeve .....	1
38	GO11-2	轴套..... Bushing.....	1
39	GS45	紧定螺钉..... Set screw.....	2
40	GR21-2	钢球..... Steel ball .....	1
41	GW2-2	弹簧..... Spring .....	1
42	GR20-2	送料牙高度调节旋钮..... Feed dog height adjusting knob.....	1
43	GS58	紧定螺钉..... Set screw.....	2
44	GR19-2	送料牙高度调节指示片..... Adjusting indicator plate.....	1

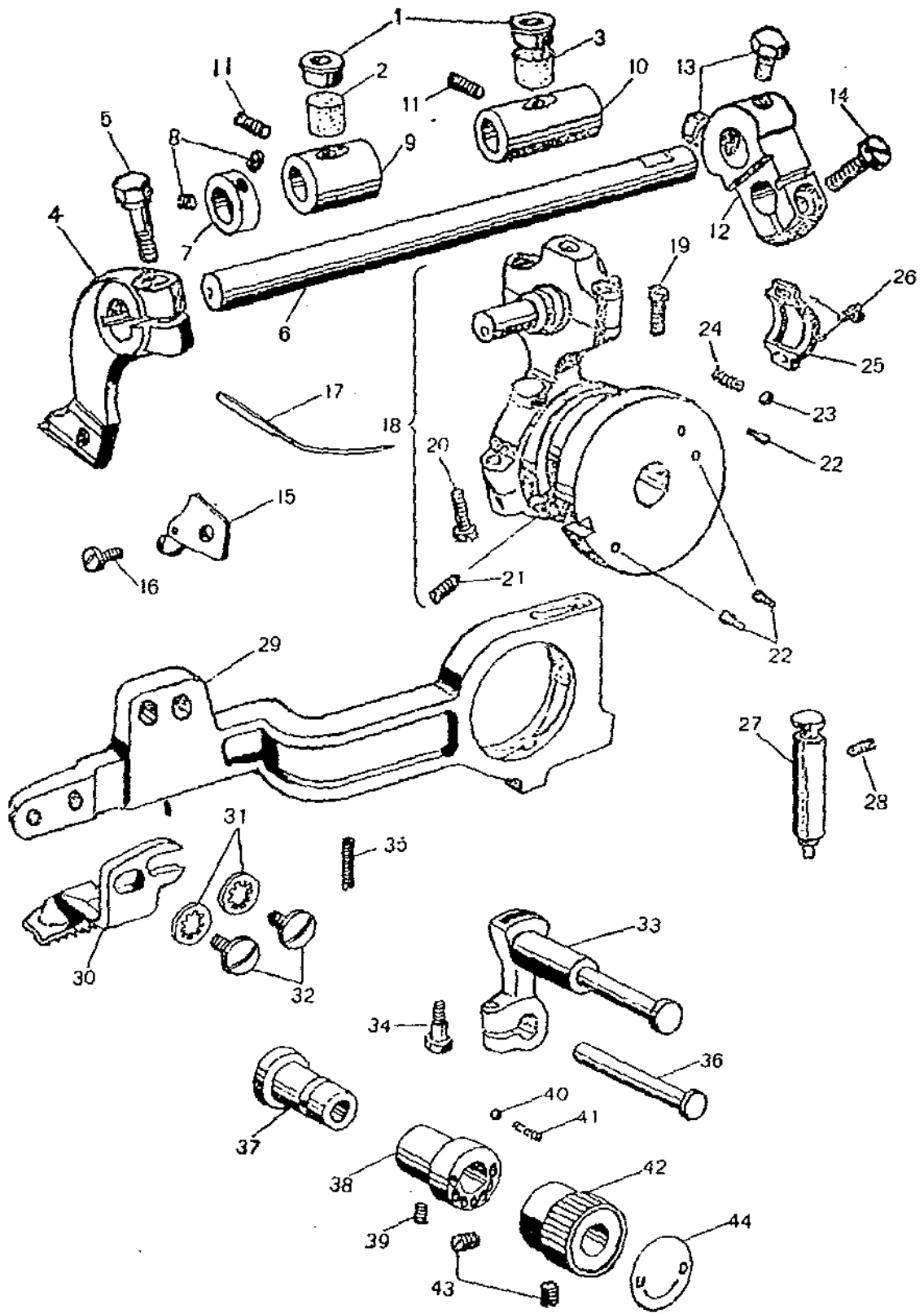

#### 4. 钩线叉部件

Thread hook components

序号	件号	名称	数量
Ref. No.	Part. No.	Description	Amt.
1	GO20-2	驱动轴定位环…… Positioning ring of driving shaft……	1
	GZ7-2	钩线叉驱动轴…… Driving shaft of thread hook……	1
	GR33-2	油毛毡…… Oil felt……	1
	GR34-2	油毡盖…… Oil felt cover……	1
	GR35-2	万向接头(后)…… Universal-joint(rear)……	1
2	GS19-2	曲柄柱头螺钉…… Crank cheese head screw……	2
3	L3	驱动轴螺母…… Driving shaft nut……	1
4	GS43	柱头螺钉…… Cheese head screw……	2
5	GR36-2	万向接头(前)…… Universal joint(front)……	1
6	GS20-2	螺钉…… Screw……	2
7	GX5-2	万向接头销…… Universal-joint pin……	1
8	GS18-2	螺钉…… Screw……	1
	GH5-2	钩线叉曲柄…… Thread hook crank……	1
9	GR39-2	摆臂(前)…… Swing arm(front)……	1
	GR38-2	摆臂(后)…… Swing arm(rear)……	1
	GR37-2	球体…… Ball element……	1
10	GZ8-2	钩线叉杆…… Thread hook lever……	1
11	GL1-2	钩线叉杆螺母…… Thread hook lever nut……	1
12	GS22-2	摆臂螺钉…… Swing arm screw……	2
13	GS21-2	摆臂紧固螺钉…… Swing arm clamp screw……	1
14	GS25-2	球体紧定螺钉…… Ball set screw……	1
15	GS23-2	钩线叉紧固螺钉…… Thread hook clamp screw……	1
16	GN1-2	钩线叉…… Thread hook……	1
17	GZ9-2	摆臂轴…… Swing arm shaft……	1
	GO21-2	偏心支承套…… Eccentric supporting sleeve……	1
18	GS17-2	紧固螺栓…… Clamp bolt……	1

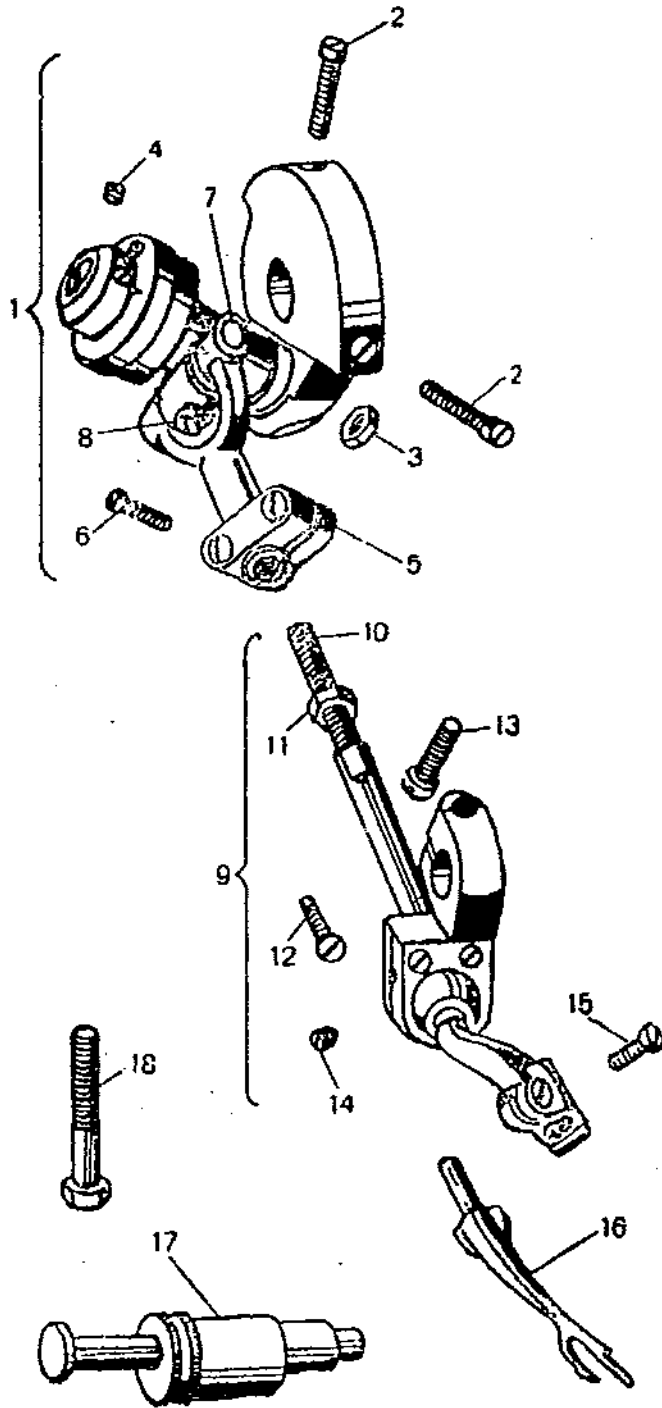

## 5. 针板组件

### Needle plate components

序号	件号	名称	数量
Ret. No.	Part. No.	Description	Amt.
1		针板组件..... Needle plate component .....	1
2	GM2-2	针板..... Needle plate .....	1
3	GR46-2	机针护板..... Needle guard .....	1
4	S16	机针护板螺钉..... Needle guard screw .....	1
5	GR47-2	导料板..... Material guide plate .....	1
6	GR34-2	导料板螺钉..... Material guide plate screw .....	1
7	GR43-2	压料板..... Material retainer.....	1
8	GS31-2	压料板螺钉..... Material retainer screw.....	1
9	GZ10-2	架轴..... Frame shaft.....	1
10	GR42-2	托架..... Bracket.....	1
11	S40	镀铬螺钉..... Chromium-plating screw.....	1
12	GW6-2	压料拉簧..... Material retainer extension spring.....	1
13	GS28-2	调节螺钉..... Adjusting screw.....	1
	GX6-2	销..... Pin.....	1
14	GR48-2	支承架..... Supporting frame .....	1
15	S40	镀铬螺钉..... Chromium-plating screw .....	1
16	GL2-2	调节螺母..... Adjusting nut.....	1
17	GR45-2	拉簧柱..... Extension spring pillar.....	1
18	GR44-2	挡线块..... Retaining block.....	1
19	GS33-2	挡线块螺钉..... Retaining block screw.....	1
20	GR49-2	抬料轮(90°)..... Ridge forming disc(90°) .....	1
21	GR50-2	抬料轮(120°)..... Ridge forming disc(120°) .....	1
	GR51-2	抬料轮(圆头)..... Ridge forming disc(round head) .....	1
22	GS27-2	针板固定大螺钉... Needle plate clamping screw (large).....	1
23	GR40-2	针板支架..... Needle plate support .....	2
24	GS26-2	支架调节螺钉..... Support regulating screw .....	2
25	GS29-2	支架固定螺钉..... Support clamping screw .....	2
26	GR203-2	平垫..... Washer .....	2
27	GS30-2	针板固定螺钉..... Needle plate clamping screw.....	2

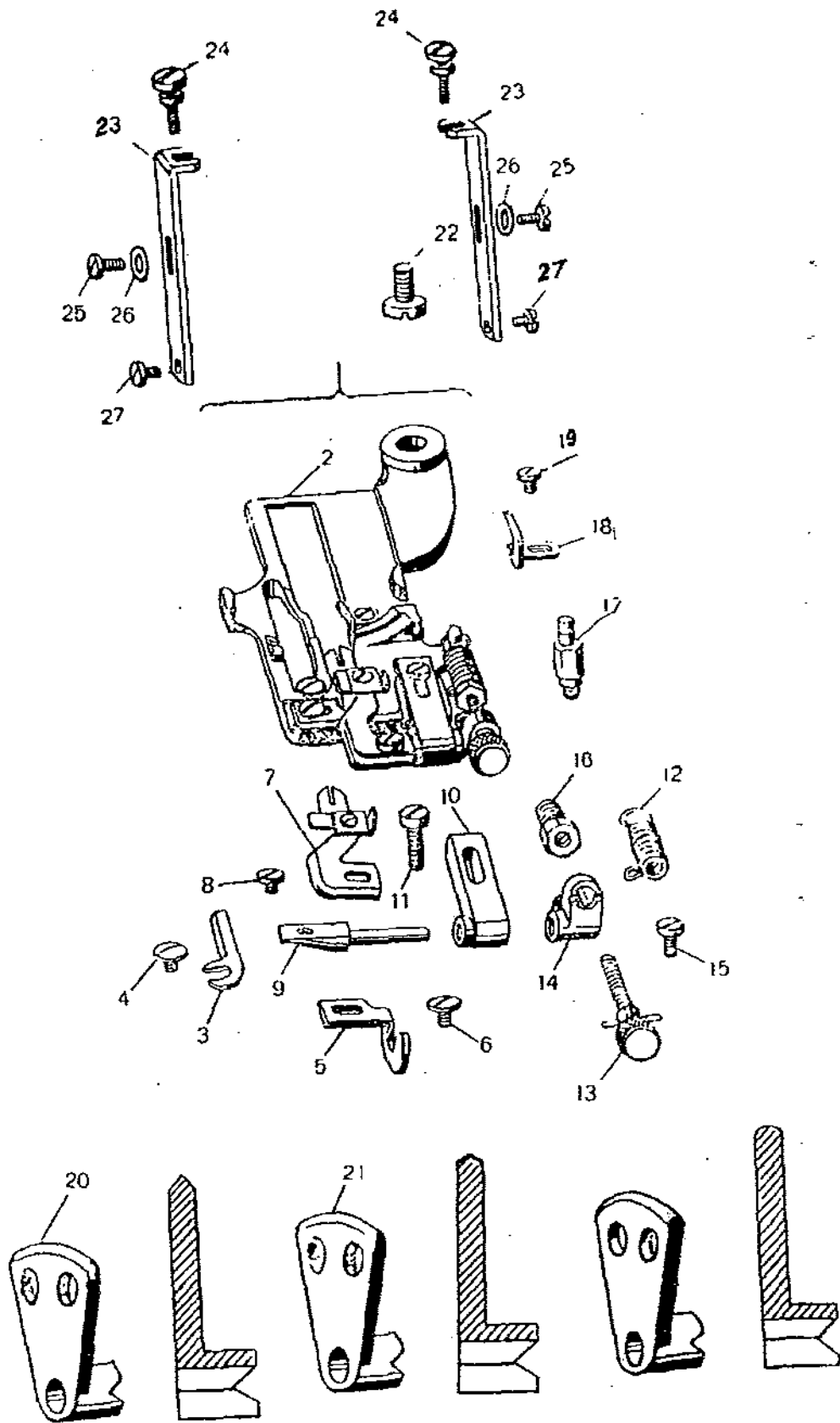

## 6. 抬料轮和抬压脚组件

Ridge forming disc and lifting presser components

序号	件号	名称	数量
Ret. No.	Part. No.	Description	Amt.
1		抬料轮... (90°, 20°前头) Ridge forming disc (90°, 120°, round head).....1	1
2	GR204-2	内齿弹性垫圈..... Spring washer with internal teeth.....1	1
3	GL3-2	六角螺母..... Hexagon nut .....1	1
4	GX106-2	弹性圆柱销..... Spring-type straight pin.....1	1
5	GZ11-2	抬料轴..... Ridge forming disc shaft.....1	1
6	GR53-2	卡圈..... Collar.....1	1
7	GS037	锁紧螺钉..... Lock screw.....1	1
8	GO22-2	垫圈..... Washer.....1	1
9	GR52-2	抬料调节杆..... Adjusting rod .....1	1
10	GS35-2	顶尖螺钉..... Pointed screw .....1	1
11	GS48	紧定螺钉..... Set screw .....1	1
12	GR54-2	小顶尖..... Small point .....1	1
13	S3	圆柱端紧定螺钉... Set screw with dog point.....1	1
14	GW7-2	弹簧..... Spring .....1	1
15	GS36-2	弹簧吊挂螺钉..... Screw .....1	1
16	GL5-2	弹簧调节螺母..... Adjusting nut .....1	1
17	GX7-2	弹簧挂销..... Pin .....1	1
18	GL4-2	六角螺母..... Hexagon nut .....1	1
19	GZ12-2	抬压脚轴..... Lifting presser shaft .....1	1
20	GO24-2	轴套..... Bushing .....1	1
21	GS48	紧定螺钉..... Set screw .....2	2
22	GO23-2	挡圈..... Retainer ring .....2	2
23	GS43	紧定螺钉..... Set screw .....1	1
24	GM3-2	压脚板(左)..... Presser plate(left) .....1	1
	GM4-2	压脚板(右)..... Presser plate(right).....1	1
	GR59-2	抬压脚杠杆(左)... Lifting presser lever(left) .....1	1
	GR60-2	抬压脚杠杆(右)... Lifting presser lever(right).....1	1
	GX9-2	小弹簧挂销..... Pin .....2	2
25	GS45-2	圆锥螺钉..... Taper screw .....2	2
26	GL8-2	六角螺母..... Hexagon nut .....2	2
27	GS43-2	轴位螺钉..... Screw with shoulder .....2	2
28	GW9-2	小弹簧..... Small spring.....2	2
29	GS44-2	小弹簧吊挂螺钉... Screw .....2	2
30	GL7-2	小弹簧调节螺母... Adjusting nut .....2	2
31	GR61-2	支板..... Support plate .....2	2
32	GS030	圆柱头螺钉..... Cheese head screw .....1	1
33	GR55-2	指示圈..... Indicator ring.....1	1
34	GS38-2	沉头螺钉..... Countersunk head screw.....1	1
35	GR58-2	旋钮..... Knob.....2	2
36	GR21-2	钢球..... Steel ball.....1	1
37	GW8-2	弹簧..... Spring.....1	1
38	GS66	圆柱头螺钉..... Cheese head screw .....2	2

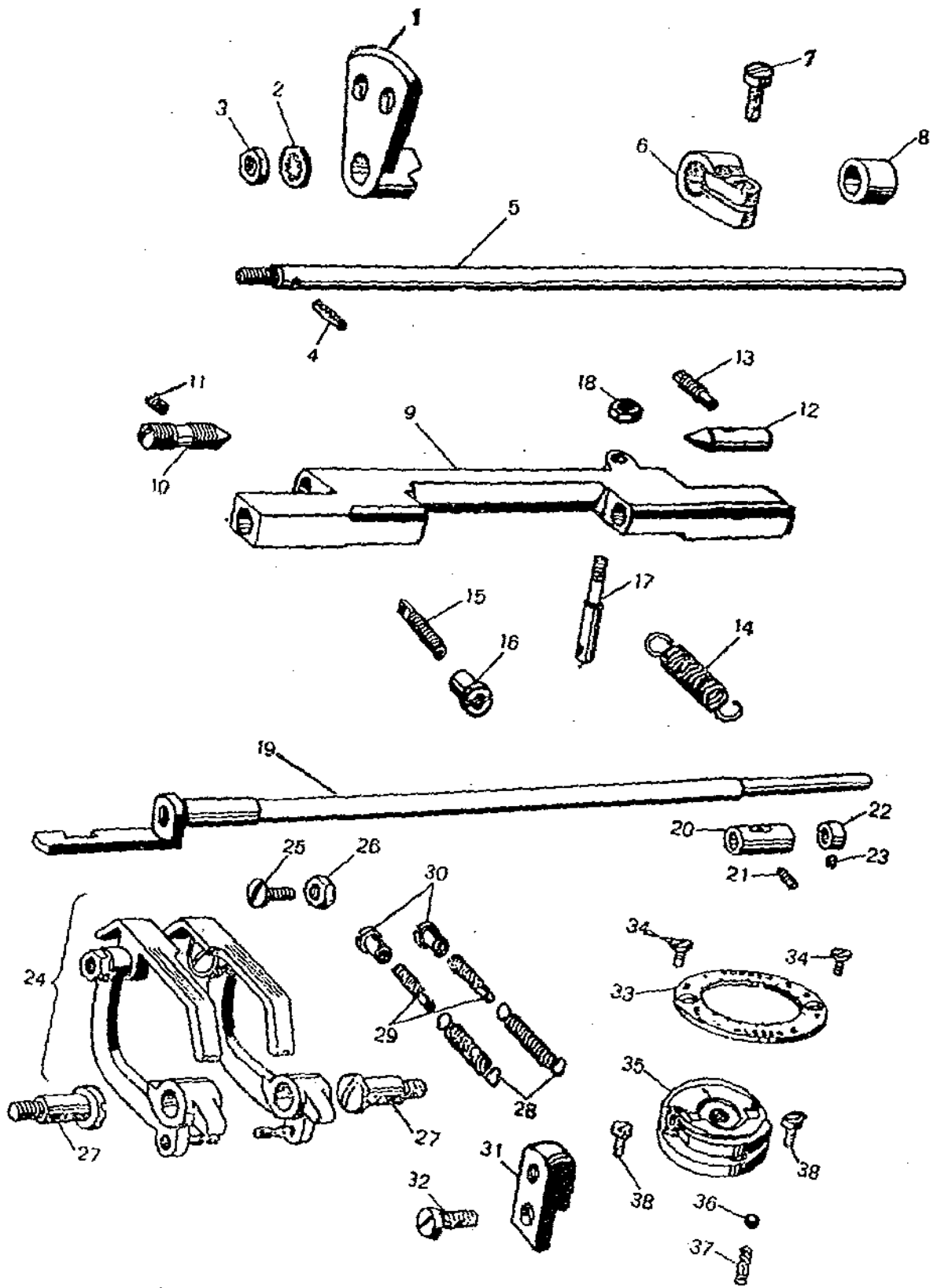



## 7. 抬料轮传动及跳针组件

Disc oscillating and skip stitch components

序号	件号	名称	数量
Ref. No.	Part. No.	Description	Amt.
1	GO28-2	左挡圈..... Retainer ring(left).....	1
2	GS50	紧定螺钉..... Set screw.....	2
3	GT1-2	止动凸轮..... Stopping cam .....	1
4	GS48	紧定螺钉..... Set screw.....	2
5	GS47-2	限位螺钉..... Limit screw.....	1
6	L1	六角螺母..... Hexagon nut.....	1
7	GO27-2	衬套..... Bushing.....	1
	GS5-2	齿轮..... Gear .....	1
8	GX13-2	摆杆..... Swing link .....	1
9	GS48	紧定螺钉..... Set screw.....	2
10	GO26-2	偏心套..... Eccentric sleeve .....	1
	GX107-2	拨销..... Pin.....	1
11	GO25-2	右挡圈..... Retainer ring(right) .....	1
12	GS50	紧定螺钉..... Set screw.....	2
13	GZ14-2	偏心轴..... Eccentric shaft.....	1
14	GR65-2	支承圈..... Supporting ring.....	1
	GX104-2	定位销..... Positioning pin.....	1
15	GS47	沉头螺钉..... Countersunk head screw .....	2
16	GR66-2	手柄..... Handle .....	1
	GR67-2	手柄座..... Base of handle .....	1
17	GS48	紧定螺钉..... Set screw.....	2
18	GS12-2	限位螺钉..... Limit screw.....	2
19	GR68-2	指示片..... Indicator plate.....	1
20	GR64-2	弹簧支承套..... Supporting sleeve.....	1
21	GW3-2	小弹簧..... Small spring .....	1
22	GR21-2	钢球..... Steel ball .....	1
23	GH7-2	曲柄..... Crank.....	1
24	GS037	锁紧螺钉..... Lock screw .....	1
25	GX10-2	连杆销..... Connecting lever pin .....	1
26	GL8-2	六角螺母..... Hexagon nut.....	1
27	GR63-2	球轴节..... Ball joint .....	1
	GH6-2	球连杆..... Ball connecting lever.....	1
28	GS46-2	轴位螺钉..... Shoulder screw .....	1
29	GR206-2	弹簧垫圈..... Spring washer.....	1
30	GL8-2	六角螺母..... Hexagon nut.....	1
31	GR62-2	撬板..... Prizing plate.....	1
32	GS58-2	摆杆螺钉..... Screw of swing link.....	2
33	GR205-2	内齿弹性垫圈..... Spring washer with internal teeth.....	2

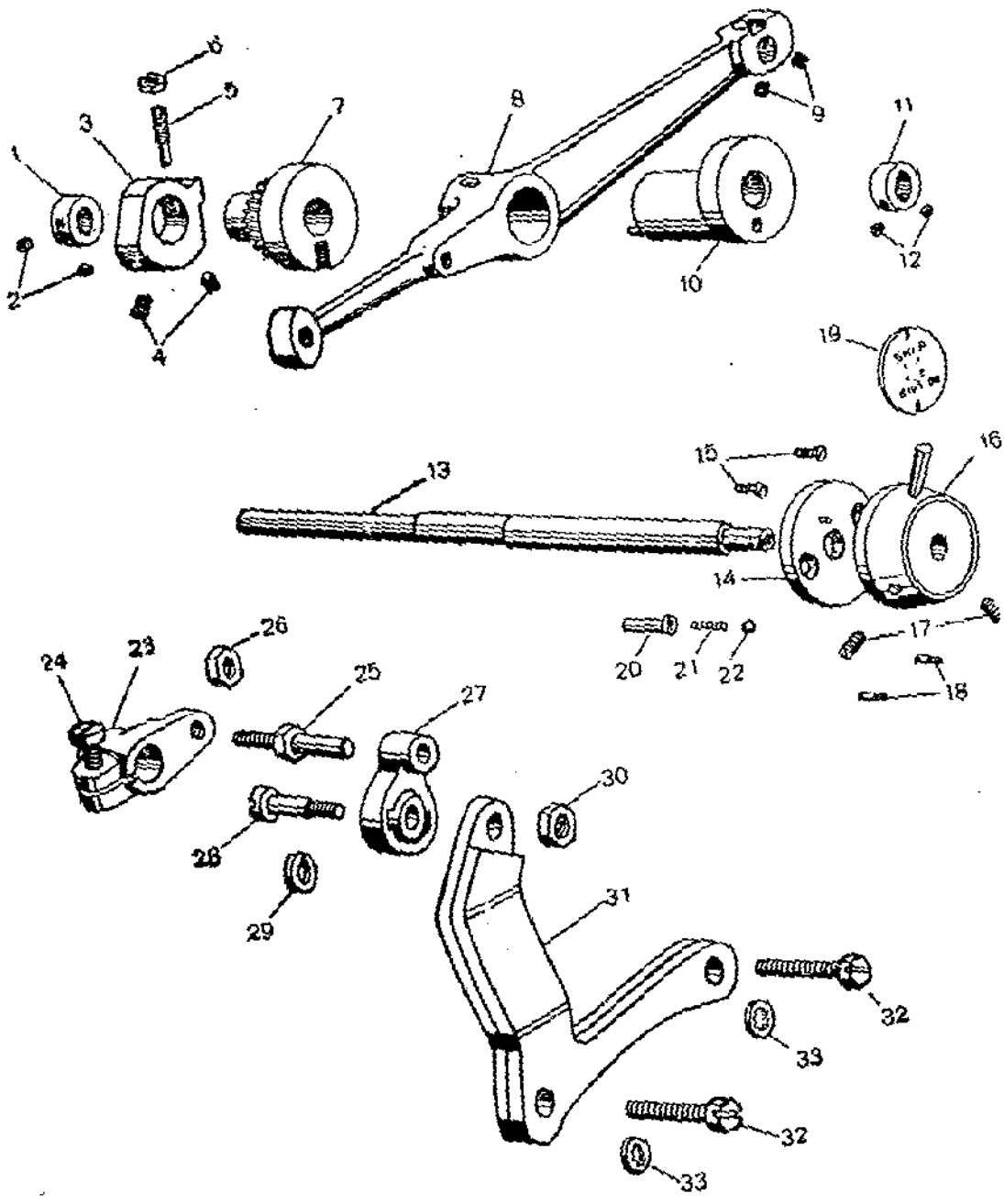

## 8. 膝提压脚及止动组件

### Disc locking mechanism and Knee lifting presser shaft parts

序号	件号	名称	数量
Ref. No.	Part. No.	Description	Amt.
1	GR72-2	止动挡块 ..... Stop dog.....	1
2	GS43	柱头螺钉 ..... Cheese head screw .....	2
3	GW11-2	扭簧 ..... Torsional spring.....	1
4	GX12-2	扭簧销 ..... Torsional spring pin.....	1
5	GZ17-2	细轴 ..... Thin shaft.....	1
6	GO29-2	限位套 ..... Limit sleeve.....	1
7	GS45	柱头螺钉 ..... Cheese head screw .....	2
8	GR207-2	轴用弹性挡圈 ..... Circlip for shaft .....	1
9	GR76-2	挡块 ..... Stop dog.....	1
10	GS43	柱头螺钉 ..... Cheese head screw .....	2
11	GZ15-2	齿轮轴 ..... Gear shaft.....	1
	GC6-2	扇形齿轮 ..... Sector gear .....	1
12	GR70-2	轴承座 ..... Bearing bracket .....	1
13	GS50-2	螺钉 ..... Screw .....	2
14	GT2-2	凸轮 ..... Cam.....	1
15	GS55-2	凹端紧定螺钉 ..... Set screw with cup point.....	2
16	GW12-2	凸轮拉簧 ..... Extension spring of cam .....	1
17	GX13-2	凸轮拉簧销 ..... Extension spring pin of cam .....	1
18	GH9-2	薄连杆 ..... Thin connecting rod .....	1
19	GS27	短铰螺钉 ..... Short hinge screw .....	1
20	GR77-2	滚子 ..... Roller.....	1
21	GS53-2	滚子螺钉 ..... Roller screw.....	1
22	GL9-2	螺母 ..... Nut .....	1
23	GH8-2	连杆 ..... Connecting rod.....	1
24	GS05	螺钉 ..... Screw .....	1
25	GZ16-2	杆 ..... Lever .....	1
26	GS52-2	铰螺钉 ..... Hinge screw .....	1
27	GR69-2	压块 ..... Balance weight.....	1
28	GS54-2	沉头螺钉 ..... Countersunk head screw.....	2
29	GR75-2	限位挡块 ..... Limit dog .....	1
30	GS037	螺钉 ..... Screw .....	1
31	GS55	螺钉 ..... Screw .....	1
32	GH10-2	弯连杆 ..... Bending connecting lever.....	1
33	GS56-2	六角头螺钉 ..... Hexagon screw .....	1
34	GS51-2	拉簧螺钉 ..... Extension spring screw.....	1
35	GR74-2	弯挡块 ..... Bending stop dog.....	1
36	GS05	螺钉 ..... Screw .....	1
37	GO31-2	轴承座 ..... Bearing sleeve.....	1
38	GS45	柱头螺钉 ..... Cheese head screw .....	1
39	GZ18-2	长轴 ..... Long shaft.....	1
40	GR71-2	套筒 ..... Sleeve.....	1
41	GS49-2	螺钉 ..... Screw .....	4
42	GW10-2	弹簧 ..... Spring.....	1
43	GX11-2	圆柱销 ..... Pin .....	1
44	GR73-2	套筒 ..... Sleeve.....	1
45	GS48-2	套筒紧固螺钉 ..... Sleeve clamp screw.....	1
46	GO30-2	垫圈 ..... Washer.....	1

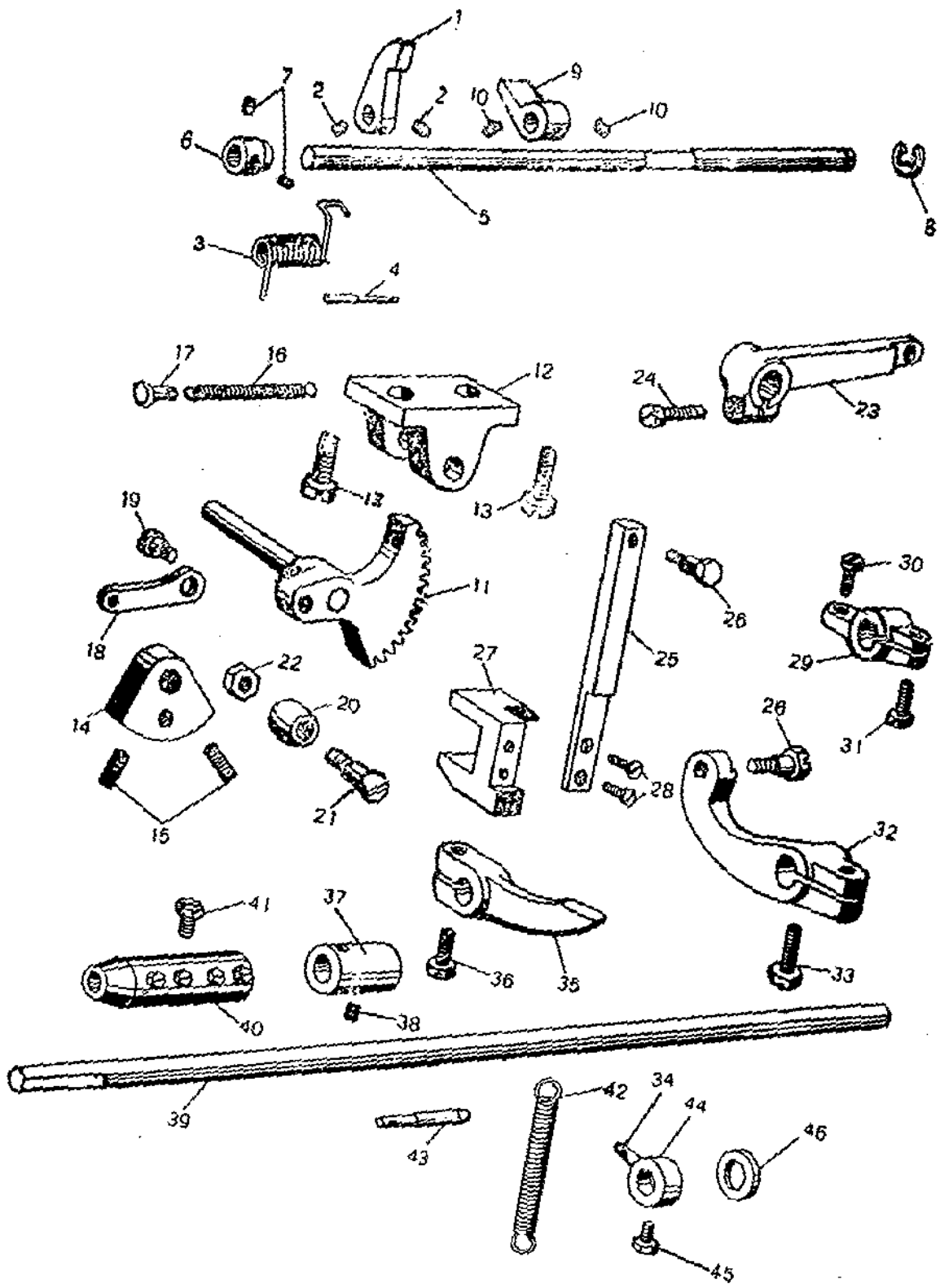

### 9. 夹线器及锁线组件

Thread tension and nipper parts components

序号	件号	名称	数量
Ref. No.	Part. No.	Description	Amt.
1	GR12-2	过线环.....Thread guide.....	1
2	GS4-2	螺钉.....Screw .....	1
3	GR13-2	过线环.....Thread guide.....	2
4	GS4-2	螺钉.....Screw .....	2
5	L5	夹线螺母.....Thread tension nut.....	1
6	GW15-2	夹线簧.....Thread tension spring .....	2
7	R57	松线板.....Thread tension releasing disc.....	1
8	GR013	夹线板.....Thread tension disc .....	1
9	GX1-2	定位销.....Positioning pin .....	1
10	GS3-2	夹线螺钉.....Thread tension screw stud.....	1
11	L1	螺母.....Nut .....	1
12	GZ1-2	顶杆.....Pushing bar .....	1
13	GW1-2	松线簧.....Thread tension releasing spring .....	1
14	GR2-2	夹线柱套.....Thread tension sleeve .....	1
15	GS48	紧定螺钉.....Set screw .....	1
16	GO2-2	松紧线偏心套.....Eccentric sleeve.....	1
17	S18	紧定螺钉.....Set screw .....	2

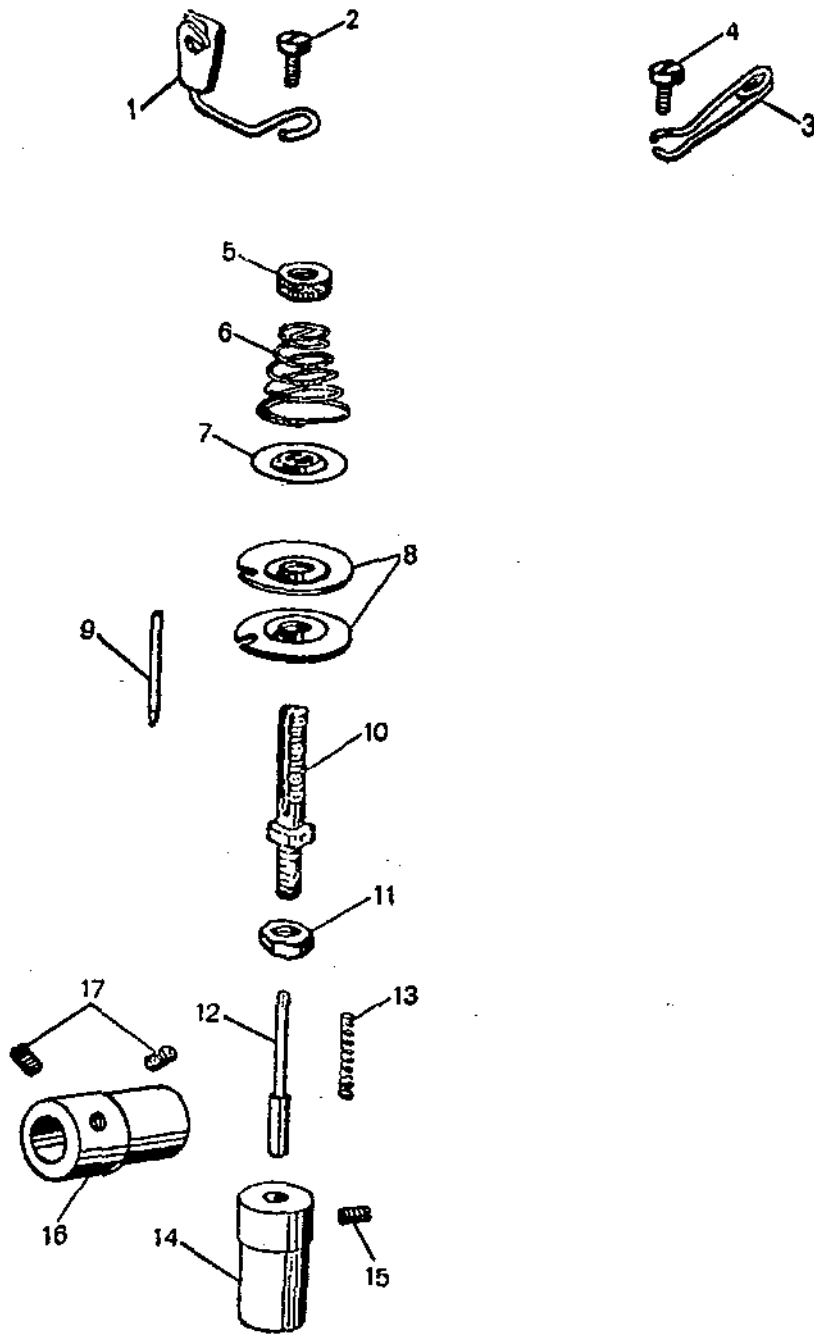

## 10 托板组件

## Work plate components

序号	件号	名称	数量
Ref. No.	Part. No.	Description	Amnt.
1	GR80-2	托板.....	1
2	GX15-2	定位销.....	1
3	GS49-2	螺钉.....	1
4	GZ20-2	托架轴.....	1
5	GS104-2	轴肩螺钉.....	1
6	GO32-2	挡圈.....	1
7	S18	挡圈螺钉.....	2
8	GS58-2	螺钉.....	2
9	GR78-2	支座.....	1
10	GS105-2	支座螺钉.....	2
11	GX14-2	顶销.....	1
12	GW14-2	长弹簧片.....	1
13	GW13-2	短弹簧片.....	1
14	GS49-2	螺钉.....	1
15	GZ19-2	膝操纵杆.....	1
16	GR83-2	膝靠板.....	1
17	GS49-2	螺钉.....	1
18	GR84-2	膝靠垫.....	1

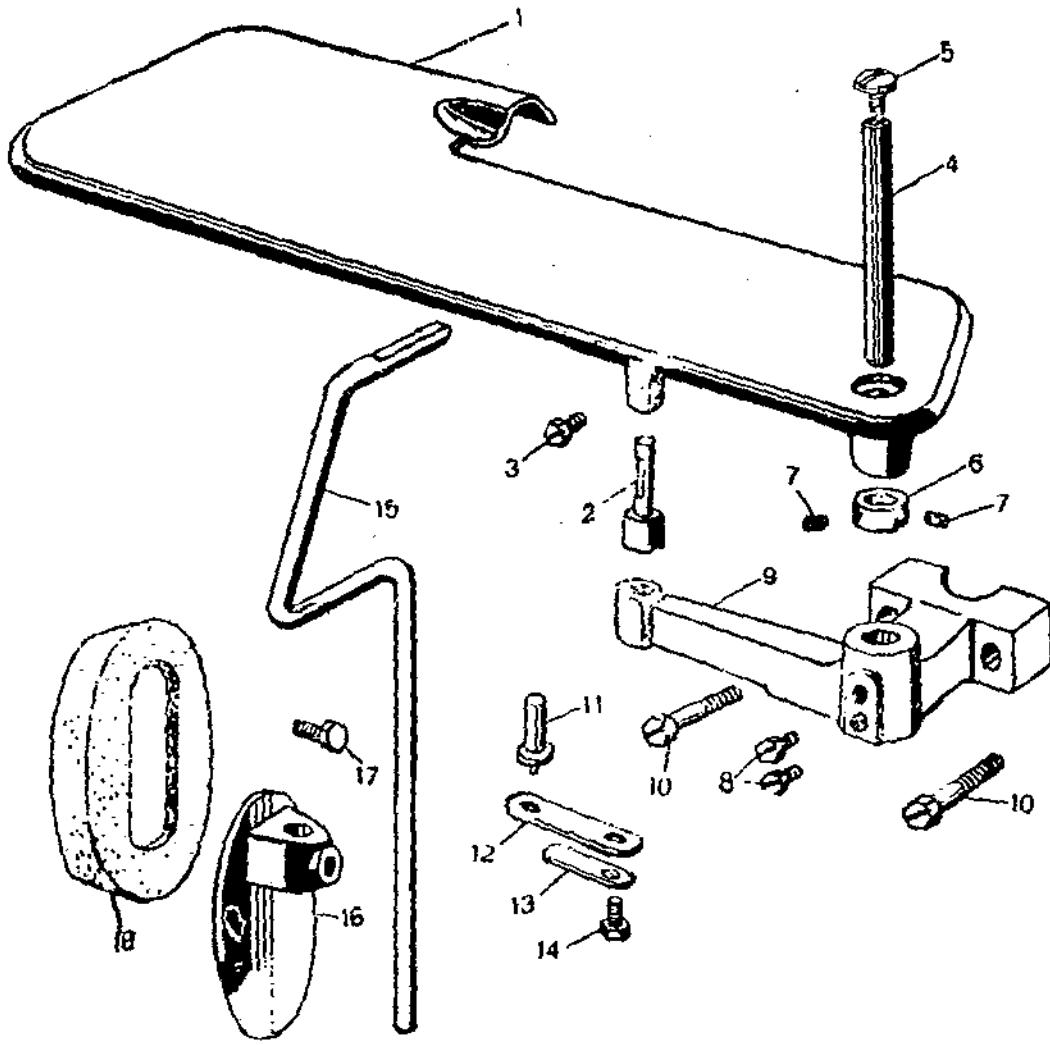





ZOJE

中捷

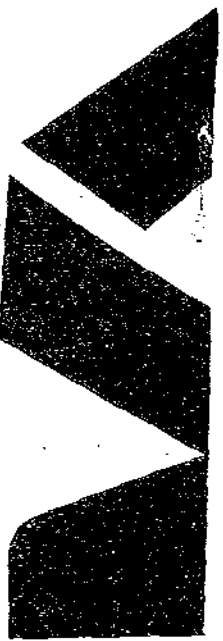

浙江中捷缝纫机有限公司  
Zhejiang ZOJE Sewing Machine Co., Ltd.  
地址: 浙江省绍兴市越城区  
电话: 0576-88222222